

VeriSens® CS-100

VS CS100M03W16EP

Article no.: 11076261

Dimension drawing

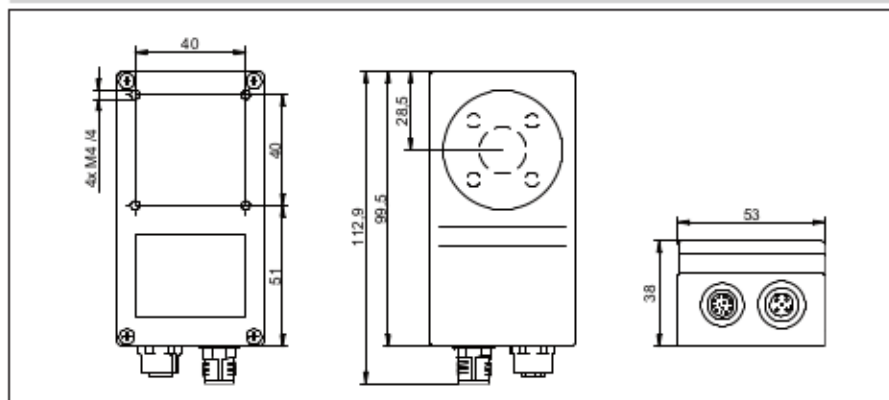

General data

Resolution, Sensor type	752 × 480 px, 1/3" CMOS (monochrome)
LED illumination	White, LED class: risk group 1 (low risk, EN 62471:2008)
Speed	
High Resolution Mode:	Max. 50 inspections per second
Lens	16 mm
Min. object distance	70 mm
Number of jobs (products)	Up to 255
Features per job	32
Fault image memory	32
Signal processing	Baumer <i>FEX</i> ® 3.5

Electrical data

Power supply	== +18 ... 30 VDC
Power consumption	Typical 5W (I _{max} = 1 A at 24 V)
Inputs	8 ... 30 VDC
Outputs	PNP 100 mA
Digital input	Trigger, Job selection, external Teach-in, Encoder (CH-A, CH-B) 500 kHz
Digital output	Pass / Fail 1-5, Flash Sync, Alarm, Camera Ready, Output Enable

Communication

Setup	Ethernet (10 Base-T / 100 Base-TX)
Process interface	-
Visualization	Web interface

Mechanical data

Width × Height × Depth	53 mm × 99.5 mm × 38 mm
Material	Housing: Aluminum, Cover glass: PMMA
Weight	250 g

Operating conditions

Operating temperature	+5 ... 50 °C
Humidity	0 ... 90 % (non-condensing)
Protection class	IP 67
Vibration load	IEC 60068-2-6, IEC 60068-2-64
Mechanical shock resistance	EN 60068-2-27

Photo



Connection (on device)

Electrical connection M12 / 12-pin



1: PWR (18-30 VDC)	7: OUT3
2: Ground	8: IN3
3: IN1 (Trigger)	9: OUT4
4: OUT1	10: IN4
5: IN2	11: IN5
6: OUT2	12: OUT5

Ethernet interface M12 / 4-pin



1: TD+	3: TD-
2: RD+	4: RD-

