



945 East 11th Avenue Tampa, FL 33605

Phone: (813) 984-0125

Contact: Sales@pyramidimaging.com

<https://pyramidimaging.com>

Spyder3 Color GigE Vision SG-34

Bilinear Color Line Scan Camera



Overview

Low-cost, ease of use, flexibility and Gigabit Ethernet Interface.

Teledyne DALSA's Spyder3 Color GigE SG-34 camera is a color line scan camera based on the successful Spyder3 dual line scan monochrome model. This camera provides a low cost solution with high color fidelity, flexibility, and ease of use.

The Spyder3 Color GigE camera has the red and blue color pixels alternating in one line and all the green pixels in the other line with no spacing between the two lines to minimize image artifact. The camera offers several color output format options, including RGB, RG/BG, or G only to meet different imaging requirements.

This camera is supported by SaperaLT and incorporates advanced features such as flat field correction, automatic white balance, and is pre-calibrated to light sources such as white LEDs, for ease of use.

Key Features

- 2k and 4k resolutions
- RGB, RG/BG, or G output formats
- Pre-calibrated light sources
- Cost-effective
- Ease of use
- GigE Vision configuration
- Supported by SaperaLT

Programmability

- Automatic white balance
- Color correction
- Bidirectional
- Flat field correction

Typical Applications

- Wood and tile inspection
- Cotton and textile
- Food, drug, and tobacco inspection
- Recycling sorting
- General machine vision

Specifications

Resolution	2048 x 2 pixels / 4096 x 2 pixels
Data Rate	80 MHz
Max. Line Rate	18 kHz / 9 kHz*
Pixel Size	14 μ m x 14 μ m (2k) 10 μ m x 10 μ m (4k)
Data Format	8 bit
Output	GigE Vision
Lens Mount	M42 x 1 (2k) M58 x 0.75 (4k)
Responsivity	8 DN / (nJ/cm ²) @ 0 dB, 8 bit (2k) 4 DN / (nJ/cm ²) @ 0 dB, 8 bit (4k)
Dynamic Range	60 dB
Nominal Gain Range	0 to +20 dB
Size	72 mm x 60 mm x 65 mm, all models
Mass	< 300 g
Operating Temp	0 °C to 65 °C (New!)
Power Supply	+12 V to +15 V
Power Dissipation	< 10.5 W
Regulatory Compliance	CE and RoHS
Control	RJ-45, 15-pin mini DSub
Data	RJ-45
Power	Hirose 6-pin
Example Part Number	SG-34-04K80-00-R

* Note: Maximum line rate may depend on data output format.

Spyder3 Color GigE Vision SG-34

Bilinear Color Line Scan Camera

The Spyder3 Color GigE camera is a cost-effective and easy-to-use bilinear color linescan camera.

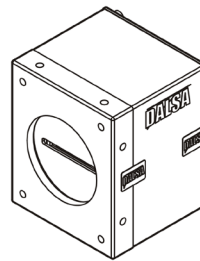
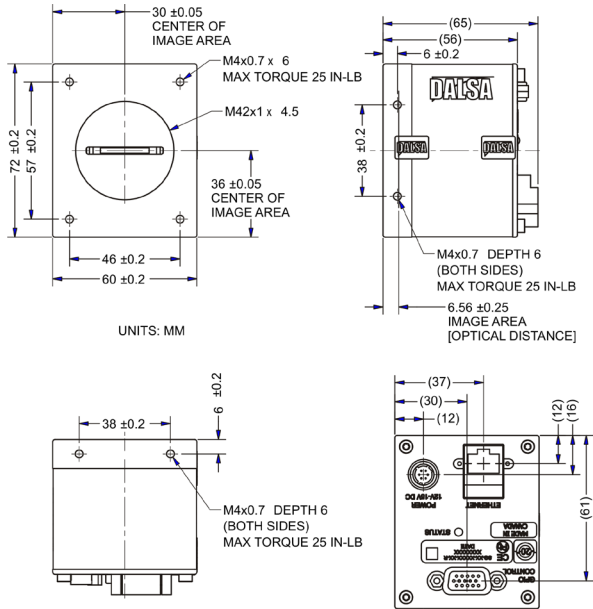

1K AND 2K MODELS

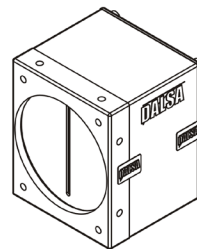
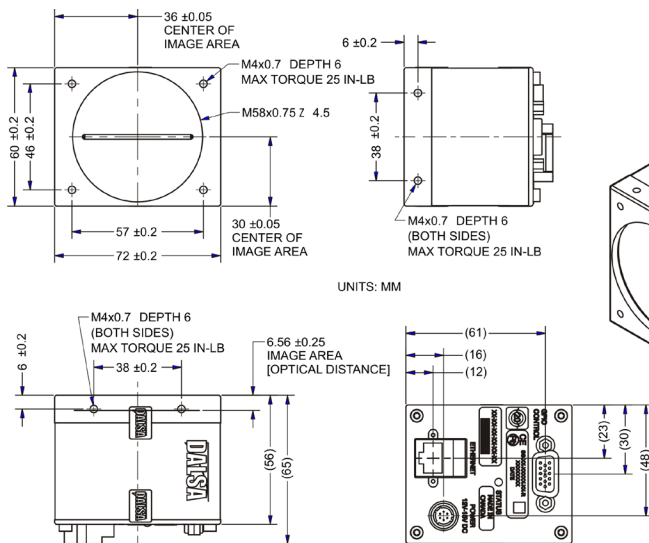
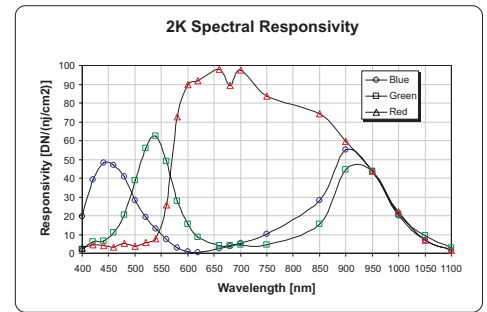

4K MODEL

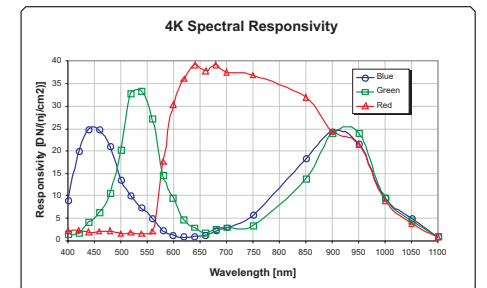

www.teledynedalsa.com

Americas

Boston, USA
Tel: +1 978-670-2000
sales.americas@teledynedalsa.com

Europe

Munich, Germany
Tel: +49 8142-46770
sales.europe@teledynedalsa.com

Asia Pacific

Tokyo, Japan
+81 3-5960-6353
sales.asia@teledynedalsa.com

Shanghai, China
+86 21-3368-0027
sales.asia@teledynedalsa.com