

Linea™ SWIR 512

SL-GA-05H04A-00-R InGaAs Line Scan Camera

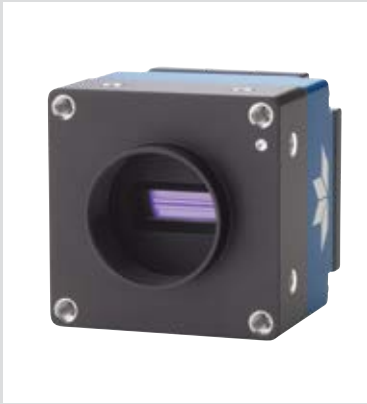

Key Features

- » 512 pixel resolution
- » 25 µm pixel size
- » 950 to 1700 nm spectral band
- » 40 kHz line rate
- » HDR mode
- » Cycling mode
- » Programmable I/Os
- » Compact form factor
- » Configurable full well
- » GigE, PoE

Typical Applications

- » Food sorting
- » Industrial sorting
- » Recycling
- » Solar panel inspection
- » Silicon wafer inspection
- » General purpose machine vision

GigE SWIR Line Scan Camera

Teledyne DALSA's 512 pixel GigE SWIR line scan camera features a cutting-edge InGaAs sensor in a compact package for a wide variety of machine vision applications.

The newest member of the Linea family features an advanced InGaAs detector with 25 µm pixels in a 512 array that offers a 40 kHz line rate. With high speed, high sensitivity, cycling mode, and programmable I/Os, the versatile Linea SWIR is ideal for applications such as optical sorting, solar panel inspection, and general purpose machine vision.

Specifications

Resolution	512 pixels			
Line Rate	40 kHz			
Pixel Pitch	25 µm			
Spectral Band	950 to 1700 nm			
Gain Setting	1	2	3	4
Max Responsivity (DN12/nJ/cm ² at 1550 nm)	20	200	800	1600
Dark Noise (DN12)	2.8	4.2	14	21
Full Well (ke-)	10,000	1,000	265	135
Dynamic Range (dB)	66	60	52	48
Peak Quantum Efficiency	66%			
Dark Current	< 5 pA			
Output Bit Depth	8, 12 bit mono			
Optical Interface	C Mount			
Control & Data	GigE			
GPIO	Programmable: 2 inputs, 2 outputs			
Camera Size	46 x 46 x 55 mm			
Camera Weight	150 g			

SPECIFICATIONS

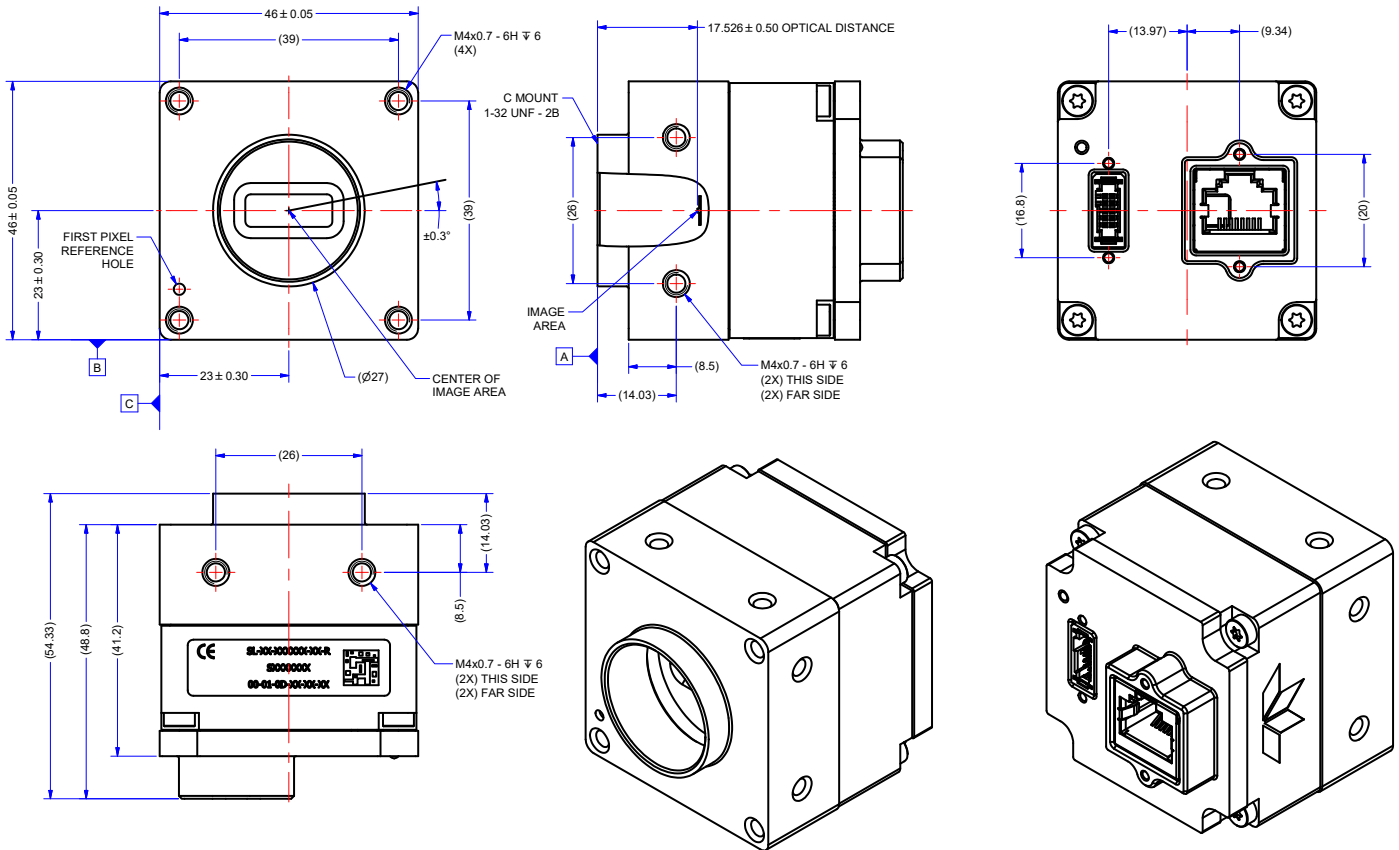
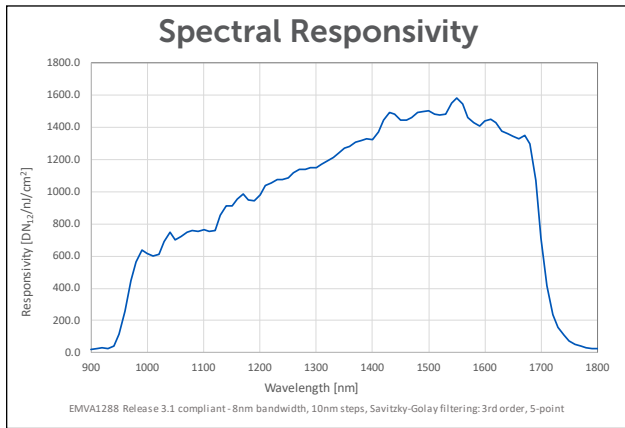

NOTES:
1. UNITS: MILLIMETERS.
2. IMAGE AREA IS ALIGNED TO DATUMS A, B & C.

Pyramid Imaging Inc • 945 East 11th Avenue • Tampa, FL 33605 • +1 813 984 0125 • sales@pyramidimaging.com • pyramidimaging.com

Americas
Boston, USA
+1 978-670-2000
sales.americas@teledynedalsa.com

Europe
Krailling, Germany
+49 89-89-54-57-3-80
sales.europe@teledynedalsa.com

Asia Pacific
Tokyo, Japan
+81 3-5960-6353
sales.asia@teledynedalsa.com

Shanghai, China
+86 21-3368-0027
sales.asia@teledynedalsa.com