

4

3

2

1

REVISIONS				
ZONE	REV.	DESCRIPTION	DATE	APPROVED
	A	RELEASED FOR PRODUCTION	10/27/2020	DMM

B

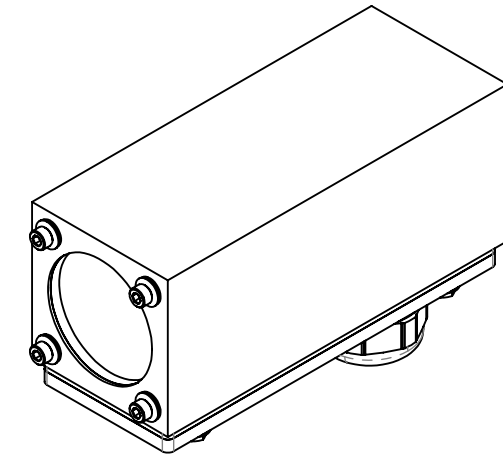
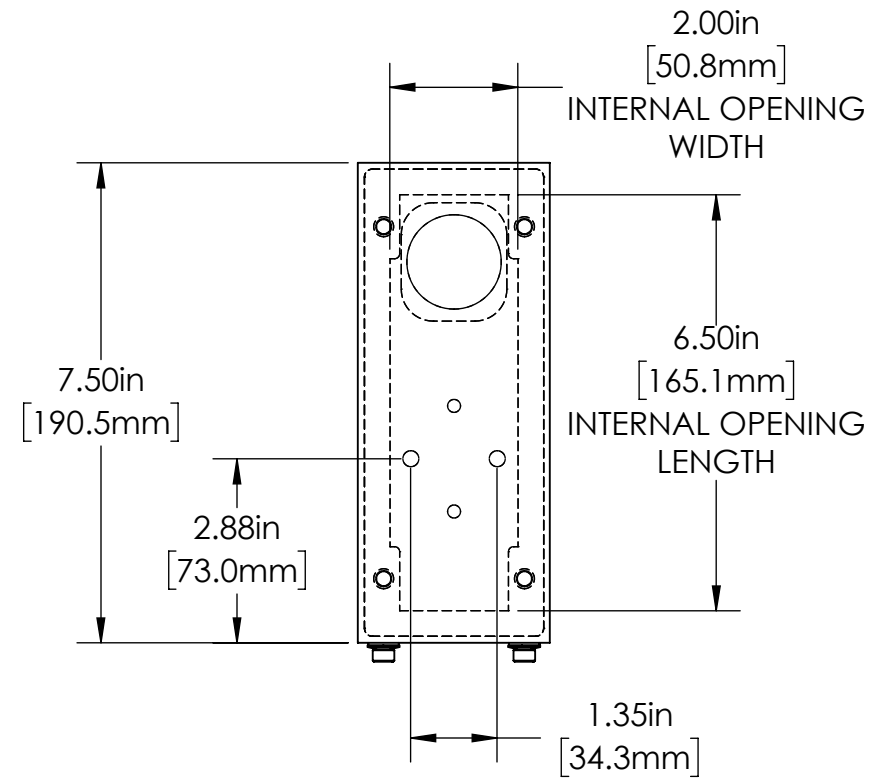

B

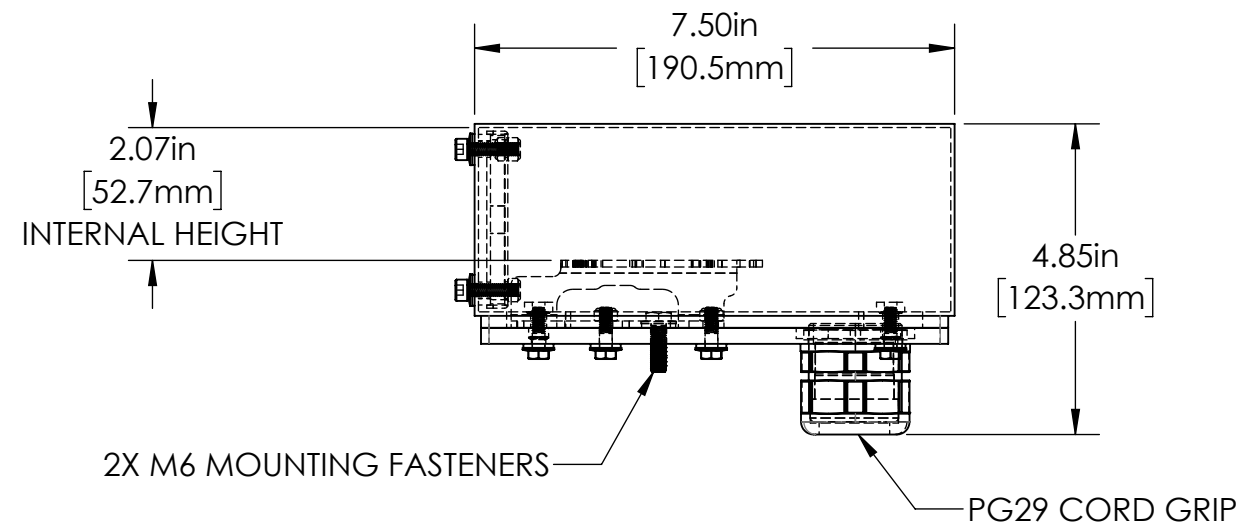
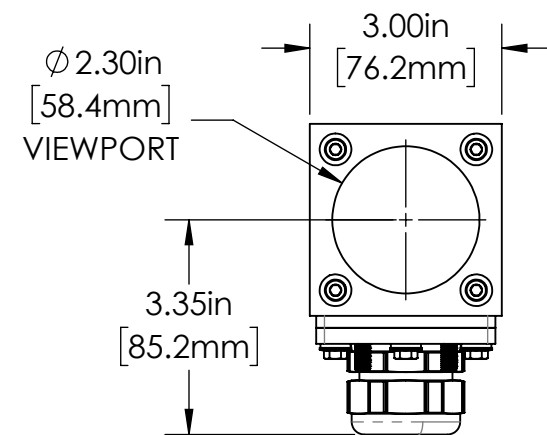

A

30D SERIES PROPERTIES TABLE		
ENVIRONMENT RATING	IP64*	
	(*RATING MAY CHANGE IF INSTALLER MILLS CABLE GLAND OUTSIDE OF TOLERANCE)	
COMPONENT	MATERIAL	FINISH
BODY	304 SS	BURNISHED
BASE	6061 ALUMINUM	CLEAR HARDCOAT ANODIZED
VIEWPORT	ACRYLIC	ABR2
GASKET	EPDM FOAM	NONE
ARM/ADAPTOR	6061 ALUMINUM	CLEAR HARDCOAT ANODIZE
HARDWARE	316 SS - EXTERNAL, 18-8 SS - INTERNAL	NONE

A



Pyramid Imaging
 Pyramid Imaging Inc
 945 East 11th Avenue
 Tampa, FL 33605
<https://pyramidimaging.com>
 Sales@pyramidimaging.com
 (813) 984-0125

TOLERANCES UNLESS OTHERWISE SPECIFIED			
MACHINING		SHEET METAL	
X.X	0.0250"	HOLE TO HOLE (SAME SURFACE)	
X.XX	0.0100"	X.X	0.030"
X.XXX	0.0050"	X.XX	0.010"
X.XXXX	0.0005"	X.XXX	0.005"
ANGULAR	0.5°	X.XXX	0.015"
DEBURR	ALL	HOLE TO FOLDED EDGE	
		X.X	0.035"
		X.XX	0.025"
		X.XXX	0.015"
		FOLD TO FOLD	
		X.X	0.045"
		X.XX	0.035"
		X.XXX	0.020"
		ANGULAR 1.0°	



THIS PRINT IS THE PROPERTY OF ALLISON PARK GROUP. THE INFORMATION CONTAINED HEREIN IS CONFIDENTIAL. IT IS NOT TRANSFERABLE. IT IS FURNISHED WITH THE CLEAR UNDERSTANDING THAT IT IS NOT TO BE TRACED, REPRODUCED OR USED IN ANY PROCESS OF MANUFACTURING WITHOUT WRITTEN PERMISSION FROM THE OWNER AND IS RETURNABLE UPON DEMAND. ANY INFRINGEMENT UPON THE PATENT RIGHTS SHOWN HEREIN, WHETHER IN PART OR WHOLE, WILL BE PROSECUTED.

AS PART OF OUR POLICY OF CONTINUING DEVELOPMENT, ALLISON PARK GROUP RESERVES THE RIGHT TO ALTER SPECIFICATIONS WITHOUT PRIOR NOTICE.

apg		Allison Park Group, Inc (APG) 4055 Alpha Drive Allison Park, PA 15101 USA Phone +1 (412) 487-8211 apgvision.com		
DESCRIPTION: 30D 7.5IN ACRYLIC UNIV. ARM R1.5 PG29				
MATERIAL:		SEE BOM		
FINISH:		SEE BOM		
DRAWN BY:	DATE:	SCALE:	SHT-SIZE:	APPROX. WEIGHT:
DMM	10/27/2020	1:3	B	
CHECKED BY:	DATE:	PART NUMBER:		REVISION:
DMM	10/27/2020	30D-FS		A
Sheet1 of 1				

4

3

2

1