

4

3

2

1

REVISIONS

ZONE	REV.	DESCRIPTION	DATE	APPROVED
	A		7/30/2019	

B

B

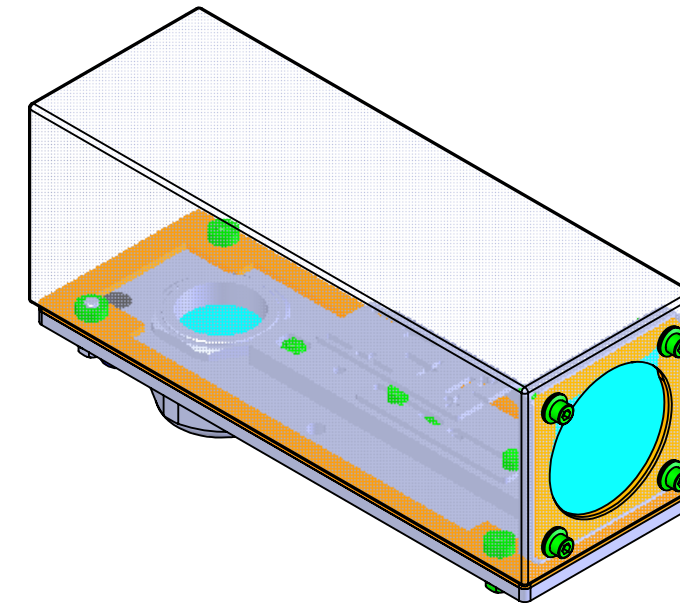
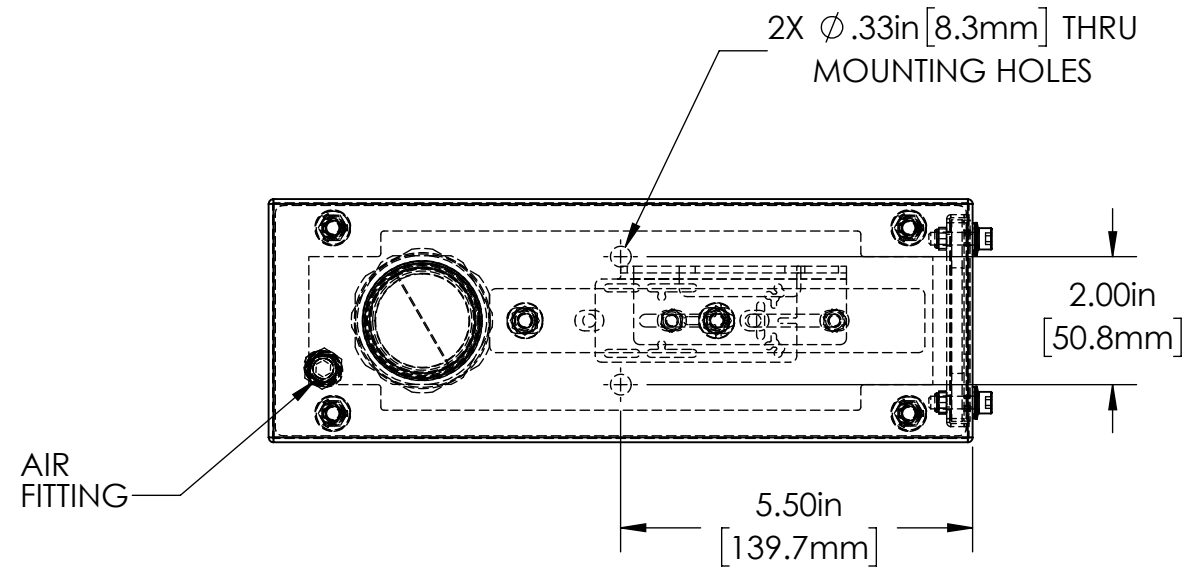

A

A

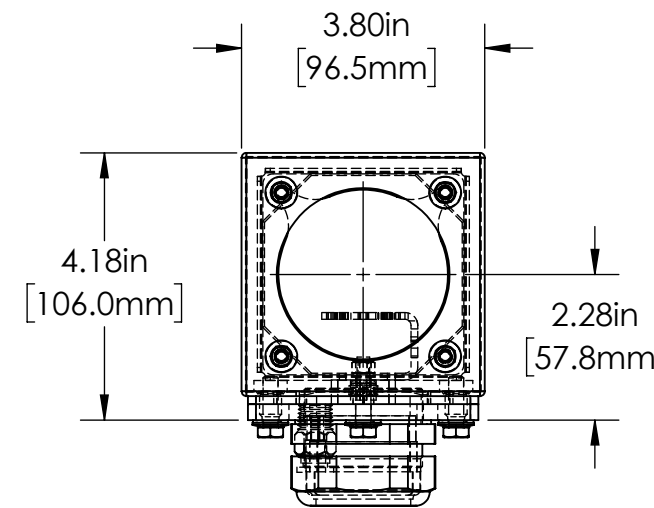
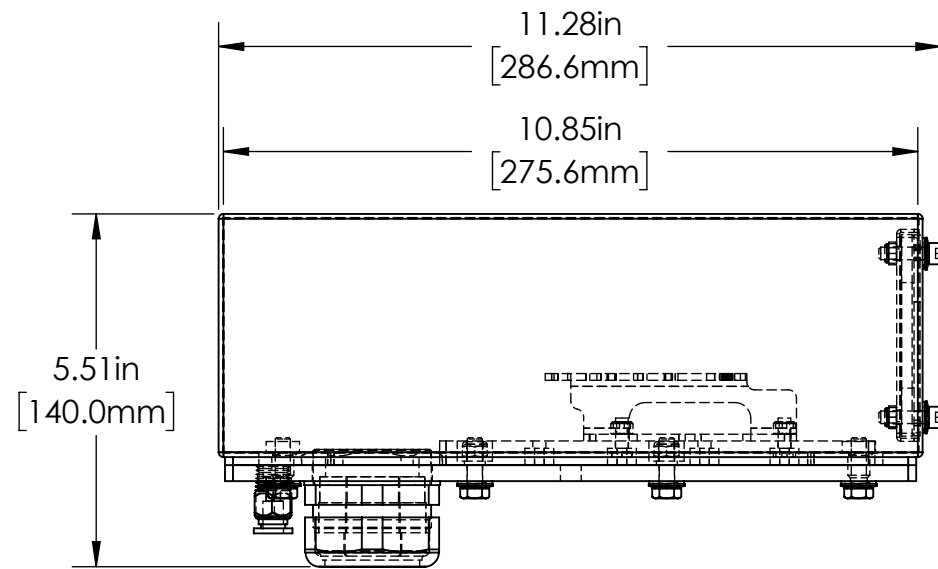

Pyramid Imaging Inc
 945 East 11th Avenue
 Tampa, FL 33605
<https://pyramidimaging.com>
 Sales@pyramidimaging.com
 (813)984-0125

MACHINING		SHEET METAL	
X.X	0.0250"	HOLE TO HOLE (SAME SURFACE)	
X.XX	0.0100"	X.X	0.030"
X.XXX	0.0050"	X.XX	0.010"
X.XXXX	0.0005"	X.XXX	0.005"
ANGULAR	0.5°	HOLE TO FOLDED EDGE	
DEBURR ALL		X.X	0.035"
		X.XX	0.025"
		X.XXX	0.015"
		FOLD TO FOLD	
		X.X	0.045"
		X.XX	0.035"
		X.XXX	0.020"
		ANGULAR 1.0°	

ALL WEIGHTS ARE IN POUNDS

THIS PRINT IS THE PROPERTY OF ALLISON PARK GROUP. THE INFORMATION CONTAINED HEREIN IS CONFIDENTIAL. IT IS NOT TRANSFERABLE. IT IS FURNISHED WITH THE CLEAR UNDERSTANDING THAT IT IS NOT TO BE TRACED, REPRODUCED OR USED IN ANY PROCESS OF MANUFACTURING WITHOUT WRITTEN PERMISSION FROM THE OWNER AND IS RETURNABLE UPON DEMAND. ANY INFRINGEMENT UPON THE PATENT RIGHTS SHOWN HEREIN, WHETHER IN PART OR WHOLE, WILL BE PROSECUTED.

AS PART OF OUR POLICY OF CONTINUING DEVELOPMENT, ALLISON PARK GROUP RESERVES THE RIGHT TO ALTER SPECIFICATIONS WITHOUT PRIOR NOTICE.



Allison Park Group, Inc (APG)
 4055 Alpha Drive
 Allison Park, PA 15101 USA
 Phone +1 (412) 487-8211
apgvision.com

DESCRIPTION: 38D-AP ENCLOSURE				
MATERIAL: SEE BOM				
FINISH: SEE BOM				
DRAWN BY: KENNEDY	DATE: 8/30/2019	SCALE: 1:3	SHT-SIZE: B	APPROX. WEIGHT: 2.9085
CHECKED BY:	DATE:	PART NUMBER: 38D-AP		REVISION: A
Sheet 1 of 1				

4

3

2

1