

4

3

2

1

REVISIONS

ZONE	REV.	DESCRIPTION	DATE	APPROVED
	A	RELEASED FOR PRODUCTION	10/23/2020	DMM

B

B

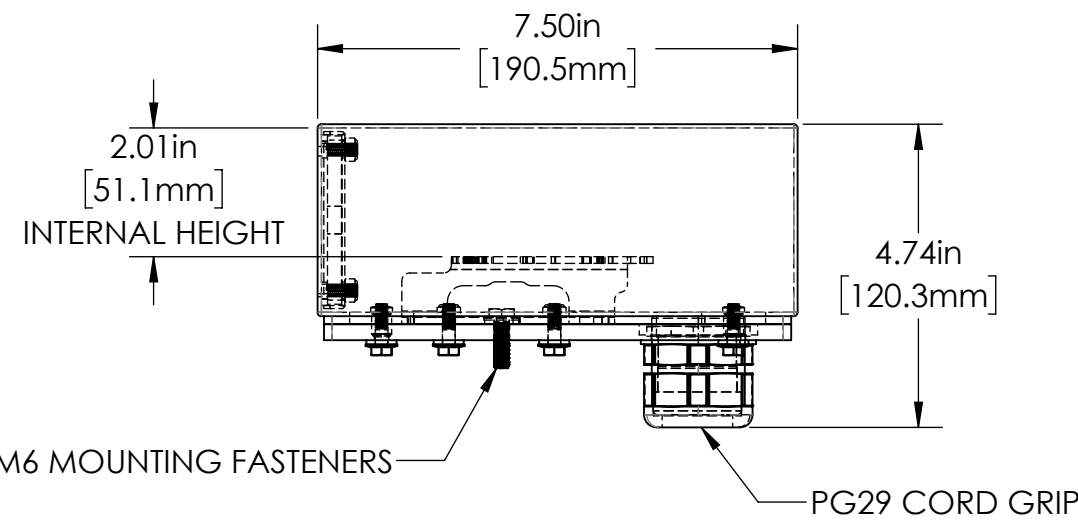
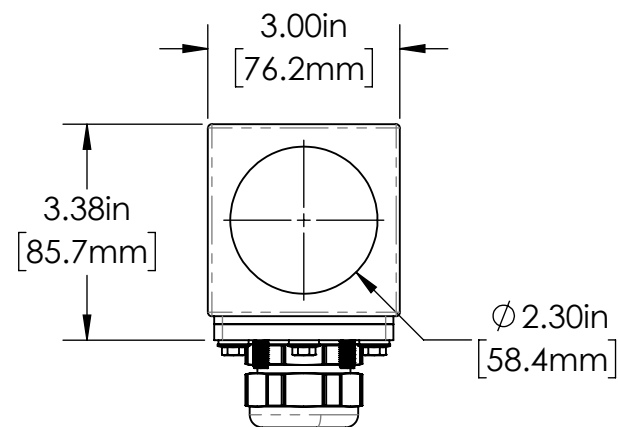
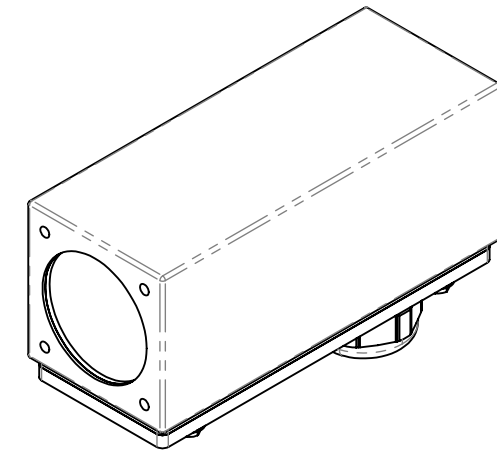
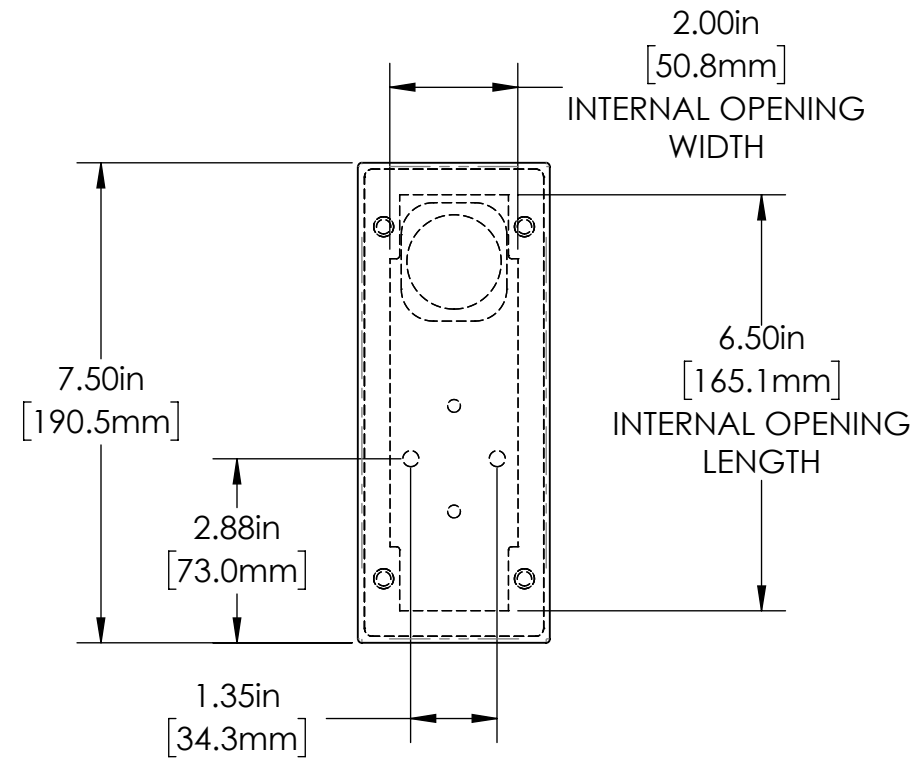

A

A

30S SERIES PROPERTIES TABLE

ENVIRONMENT RATING	IP68*	
	(*RATING MAY CHANGE IF INSTALLER MILLS CABLE GLAND OUTSIDE OF TOLERANCE)	
COMPONENT	MATERIAL	FINISH
BODY	316 SS	BURNISHED
VIEWPORT	CLEAR ACRYLIC	ABR2
GASKET	40D SILICONE	NONE
ARM/ADAPTOR	5052 ALUM	AS SUPPLIED
HARDWARE	316 SS - EXTERNAL, 18-8 SS - INTERNAL	AS SUPPLIED



Pyramid Imaging

Pyramid Imaging Inc
 945 East 11th Avenue
 Tampa, FL 33605
<https://pyramidimaging.com>
 Sales@pyramidimaging.com
 (813) 984-0125

TOLERANCES UNLESS OTHERWISE SPECIFIED			
MACHINING		SHEET METAL	
X.X	0.0250"	HOLE TO HOLE (SAME SURFACE)	
X.XX	0.0100"	X.X	0.030"
X.XXX	0.0050"	X.XX	0.010"
X.XXXX	0.0005"	X.XXX	0.005"
ANGULAR	0.5°	HOLE TO FOLDED EDGE	
DEBURR ALL		X.X	0.035"
		X.XX	0.025"
		X.XXX	0.015"
		FOLD TO FOLD	
		X.X	0.045"
		X.XX	0.035"
		X.XXX	0.020"
		ANGULAR 1.0°	



THIS PRINT IS THE PROPERTY OF ALLISON PARK GROUP. THE INFORMATION CONTAINED HEREIN IS CONFIDENTIAL. IT IS NOT TRANSFERABLE. IT IS FURNISHED WITH THE CLEAR UNDERSTANDING THAT IT IS NOT TO BE TRACED, REPRODUCED OR USED IN ANY PROCESS OF MANUFACTURING WITHOUT WRITTEN PERMISSION FROM THE OWNER AND IS RETURNABLE UPON DEMAND. ANY INFRINGEMENT UPON THE PATENT RIGHTS SHOWN HEREIN, WHETHER IN PART OR WHOLE, WILL BE PROSECUTED.

AS PART OF OUR POLICY OF CONTINUING DEVELOPMENT, ALLISON PARK GROUP RESERVES THE RIGHT TO ALTER SPECIFICATIONS WITHOUT PRIOR NOTICE.



Allison Park Group, Inc (APG)
 4055 Alpha Drive
 Allison Park, PA 15101 USA
 Phone +1 (412) 487-8211
 apgvision.com

DESCRIPTION: 30S 7.5IN ACRYLIC UNIV. ARM R1.5 SEALED PG29				
MATERIAL: SEE BOM				
FINISH: SEE BOM				
DRAWN BY: DMM	DATE: 10/23/2020	SCALE: 1:3	SHT-SIZE: B	APPROX. WEIGHT
CHECKED BY: DMM	DATE: 10/23/2020	PART NUMBER: 30S-IH		REVISION: A

4

3

2

1