

4

3

2

1

REVISIONS				
ZONE	REV.	DESCRIPTION	DATE	APPROVED
	A	RELEASED FOR PRODUCTION	10/26/2020	DMM

B

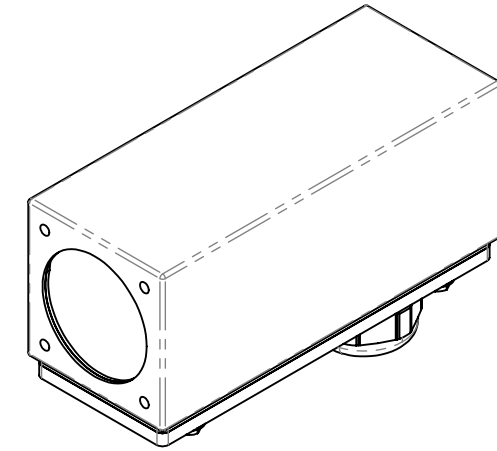
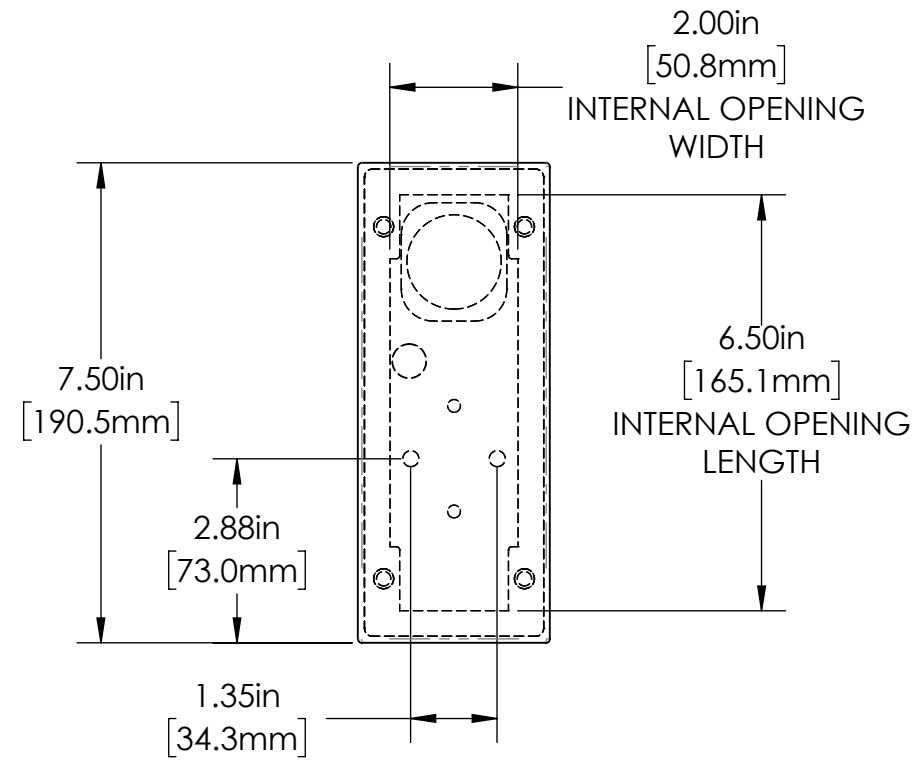

B

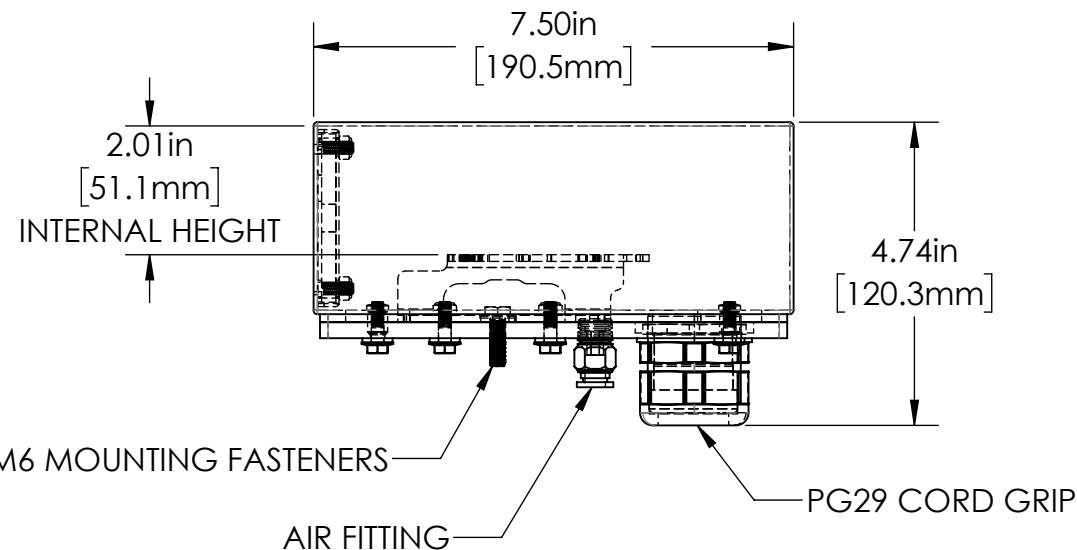
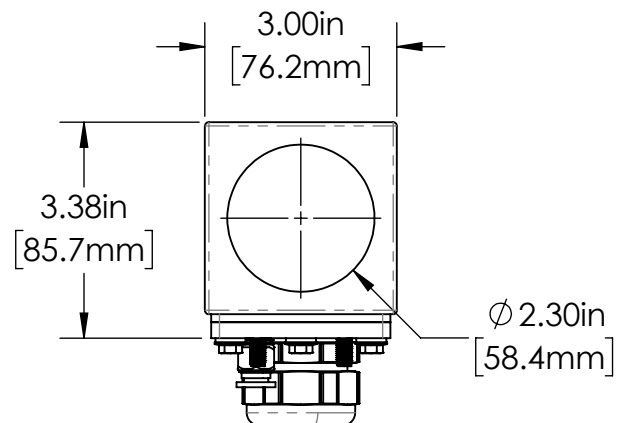

A

30S SERIES PROPERTIES TABLE		
ENVIRONMENT RATING	IP68*	
	(*RATING MAY CHANGE IF INSTALLER MILLS CABLE GLAND OUTSIDE OF TOLERANCE)	
COMPONENT	MATERIAL	FINISH
BODY	316 SS	BURNISHED
VIEWPORT	CLEAR ACRYLIC	ABR2
GASKET	40D SILICONE	NONE
ARM/ADAPTOR	5052 ALUM	AS SUPPLIED
HARDWARE	316 SS - EXTERNAL, 18-8 SS - INTERNAL	AS SUPPLIED



Pyramid Imaging Inc  
 945 East 11th Avenue  
 Tampa, FL 33605  
<https://pyramidimaging.com>  
 Sales@pyramidimaging.com  
 (813) 984-0125

TOLERANCES UNLESS OTHERWISE SPECIFIED			
MACHINING		SHEET METAL	
X.X	0.0250"	HOLE TO HOLE (SAME SURFACE)	
X.XX	0.0100"	X.X	0.030"
X.XXX	0.0050"	X.XX	0.010"
X.XXXX	0.0005"	X.XXX	0.005"
ANGULAR	0.5°	X.XXX	0.015"
DEBURR ALL		HOLE TO FOLDED EDGE	
		X.X	0.035"
		X.XX	0.025"
		X.XXX	0.015"
		FOLD TO FOLD	
		X.X	0.045"
		X.XX	0.035"
		X.XXX	0.020"
		ANGULAR 1.0°	

		Allison Park Group, Inc (APG) 4055 Alpha Drive Allison Park, PA 15101 USA Phone +1 (412) 487-8211 apgvision.com		
DESCRIPTION: <b>30S 7.5IN ACRYLIC UNIV. ARM R1.5 AIR CURTAIN PG29</b>				
MATERIAL:		SEE BOM		
FINISH:		SEE BOM		
DRAWN BY:	DATE:	SCALE:	SHT-SIZE:	APPROX. WEIGHT
DMM	10/26/2020	1:3	B	
CHECKED BY:	DATE:	PART NUMBER:		REVISION
DMM	10/26/2020	30S-IJ		A
Sheet1 of 1				

4

3

2

1

A