

EoSens® 2.0CXP2

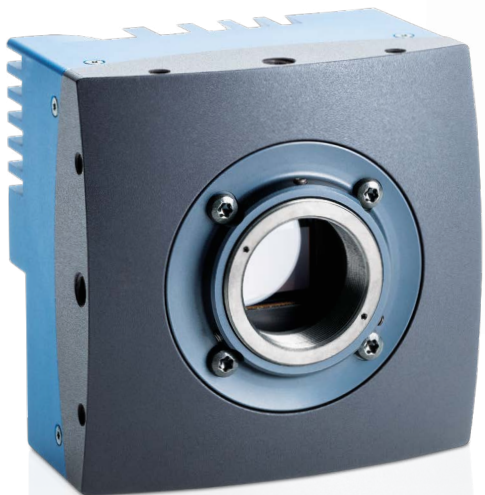

Pyramid Imaging
945 East 11th Avenue Tampa, FL 33605
sales@pyramidimaging.com
www.pyramidimaging.com
813-786-3785



GEN*i*CAM

CoaXPress

CXP-12

Engineered for highest Performance

Featuring a high-speed CMOS sensor, the EoSens® 2.0CXP2 offers full HD 1,920 x 1,080 pixel resolution at an out-standing speed of 2,220 fps. The camera takes advantage of the new CoaXPress Standard Version 2.0 transmitting data at twice the data rate of Version 1.1. The CXP-12 interface supports data transmission of up to 4 lanes at 12.5 Gpbs.

High Sensitivity

The camera's extreme sensitivity of 20 V/lux*s @ 550 nm delivers high-contrast images even in very low light conditions. This allows to integrate it in applications where lighting is the crucial point.

EoSens® 2.0CXP2 Key Features:

- 2,220 fps at 2 megapixel resolution
- Up to 170,500 fps at reduced resolution
- High sensitivity
- Fast CoaXPress-12 interface
- 80 x 80 x 53 mm small

APPLICATION EXAMPLES

- Melt pool monitoring
- Additive Manufacturing
- Ball grid inspection
- Sorting
- PIV measurements
- Inspection
- Roboter positioning
- Microscopy

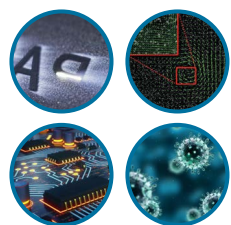

MIKROTRON
High-Speed Vision Solutions

Compact Design

Contained within an 80 x 80 x 53 mm in a fanless metal housing and an integrated CoaXPress interface, the EoSens® 2.0CXP2 is suited for use in a wide range of industrial applications.

Frame rates

Resolution	Frame rate
1,920 x 1,080 px	2,220 fps
1,280 x 1,024 px	2,350 fps
1,280 x 764 px	3,150 fps
640 x 480 px	5,010 fps
128 x 128 px	18,160 fps
	Max. 170,500

Smart Features

- CoaXPress lanes switchable 1, 2 or 4
- Link speed switchable down to 3,125 Gbps (CoaXPress 1.1 compatible)
- Gamma Correction
- FPN Correction

Technical Data

(More detailed specifications are available on request)

EoSens® 2.0CXP2 monochrome / color	
Resolution	2 Mpix
Active pixels	1,920 x 1,080 px
Interface	CoaXPress® @ 4 x 12.5 Gbit/s
Frame rate (8 bit)	2,220 fps
Sensor	LUX19HS
Sensor type	CMOS global shutter
Sensor format	4/3"
Pixel size	10 x 10 µm
Sensitivity	20 V/lux*s @ 550 nm
Pixel data width	10 / 8 bit
Dynamic range	60 dB
Shutter time (steps)	1 µs
Shutter time (range)	2 µs – 1 s
Max. Jitter via CXP Trigger	±4 ns
Mount options	C-Mount / F-Mount
Dimensions (W x H x L w/o mount)	80 x 80 x 53 mm
Weight (C-Mount)	450 g
Power consumption	11 W
Power supply	12 – 24 VDC
Camera body temperature	+5 °C ... +50 °C
Shock / Vibration proof	70 g / 7 grms
Conformity	CoaxPress / GenICam / CE / RoHS

Camera Body Dimensions

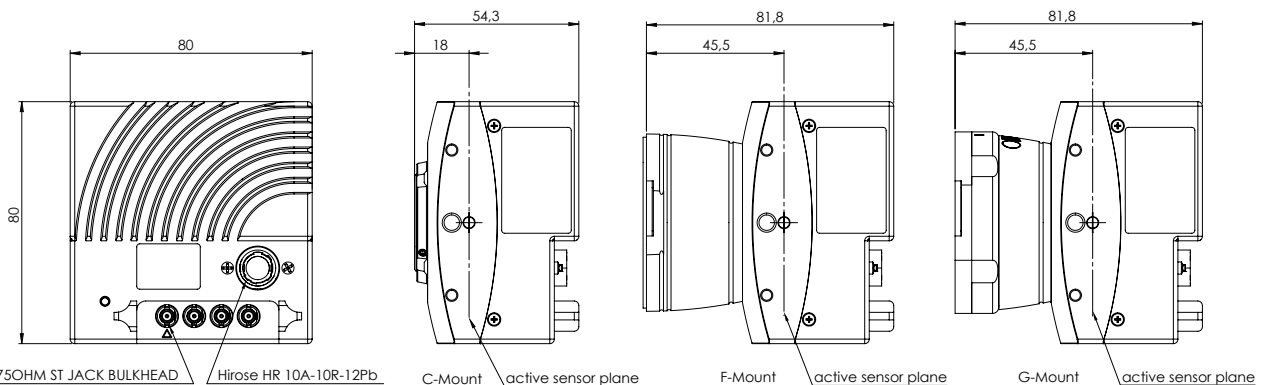

MIKROTRON GmbH

MIKROTRON GmbH provides a full range of high-speed imaging solutions for challenging applications in industry, engineering, science and sports. The company's extreme slow-motion recording solutions enable customers to optimize manufacturing processes, improve product design, revolutionize quality management and analyze motion.

Germany
Landshuter Str. 20-22
85716 Unterschleissheim
+49(0)89-726342-00
info@mikrotron.de
www.mikrotron.de

North America
14032 Hermosillo Way
US-Poway, CA 92064
+1-858-774-1176
steve.ferrell@mikrotron.de
www.mikrotron.de



member of the TKH Group <