



Genie™ Nano 5GigE Cameras

Smaller, faster, stronger, cheaper.

Compact GigE Vision cameras with unprecedented speed and uncompromised image quality.

Introducing the Genie Nano-5G, a GigE Vision CMOS area scan camera that redefines **high** performance. Genie Nano starts with industry leading image CMOS sensors from 3.2 to 45 megapixel and adds proprietary camera technology for **breakthrough speed**, a robust build quality for wide operating temperature, and an unmatched feature set — all at an **incredible price**. Teledyne DALSA's proprietary **TurboDrive™** technology allows Genie Nano to deliver its full image quality at faster frame rates — often 150% or higher. Like all Teledyne DALSA GigE cameras, the Genie Nano-5G is based on AIA GigE Vision Standard to directly link the camera to a PC.

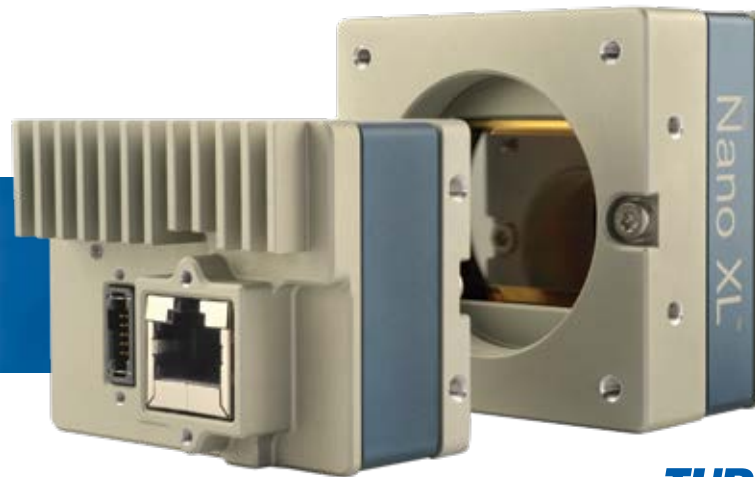

TURBODRIVE 
BY TELEDYNE DALSA

Key Features

- 5 GigE Ethernet port & hardware
- Supports cable lengths up to 100 m (CAT-5e, CAT-6) or (4T-6A)
- Simplified set-up with field proven Sopera LT software featuring CamExpert
- Engineered to accommodate industrial environment with a ruggedized screw mount RJ-45 connector

Programmability

- Higher frame rates achievable in partial scan mode
- Global electronic shutter with exposure control
- Multi-exposure feature
- Multi-ROI feature
- Metadata support
- IEEE1588 (Precision Time Protocol) support
- Binning
- Look-up-table and More

Reliability

- Robust all-metal body
- 3 year warranty
- Trigger to Image Reliability (T2IR) framework improves the reliability of your inspection system and protects you from data loss

Typical Applications

- Electronics manufacturing inspection
- Industrial metrology
- Intelligent traffic systems
- Aerial Imaging
- Sport and Entertainment

Regulatory Compliance

- CE, FCC and RoHS

GENIE NANO INDIVIDUAL MODEL SPECIFICATIONS

	Active Resolution	Sensor Model	Frame Rate (Burst Mode)	Pixel Size	Dynamic Range	Max. Image Circle	Data Format	Part Number
●● Nano-5G-M2050	2064 x 1544	Sony IMX252	187 fps	3.45 µm	76.46 dB	1/1.8" Optical Format	8-Bit Mono	G5-GM30-M2050
●●● Nano-5G-C2050	2064 x 1544	Sony IMX252	187 fps	3.45 µm	76.46 dB	1/1.8" Optical Format	8-Bit Raw Bayer	G5-GC30-C2050 G5-GC30-C2050IF (with IR cut-off filter)
●● Nano-5G-M2450	2464 x 2056	Sony IMX250	141 fps	3.45 µm	76.46 dB	2/3" Optical Format	8-Bit Mono	G5-GM30-M2450
●●● Nano-5G-C2450	2464 x 2056	Sony IMX250	141 fps	3.45 µm	76.46 dB	2/3" Optical Format	8-Bit Raw Bayer	G5-GC30-C2450 G5-GC30-C2450IF (with IR cut-off filter)
●● Nano-5G-M4060	4112 x 2176	Sony IMX255	87.5 fps	3.45 µm	76.46 dB	1" Optical Format	8-Bit Mono	G5-GM30-M4060
●●● Nano-5G-C4060	4112 x 2176	Sony IMX255	87.5 fps	3.45 µm	76.46 dB	1" Optical Format	8-Bit Raw Bayer	G5-GC30-C4060 G5-GC30-C4060IF (with IR cut-off filter)
●● Nano-5G-M4040	4112 x 3008	Sony IMX253	63 fps	3.45 µm	76.46 dB	1.1" Optical Format	8-Bit Mono	G5-GM30-M4040
●●● Nano-5G-C4040	4112 x 3008	Sony IMX253	63 fps	3.45 µm	76.46 dB	1.1" Optical Format	8-Bit Raw Bayer	G5-GC30-C4040 G5-GC30-C4040IF (with IR cut-off filter)
●● Nano-5G-M4500	4500 x 4500	On-semi XGS20000	30 fps	3.2 µm	66.06 dB	1.3" Optical Format	8 or 12-bit* Mono	G5-GM31-M4505
●●● Nano-5G-C4500	4500 x 4500	On-semi XGS20000	30 fps	3.2 µm	66.0 dB	1.3" Optical Format	8 or 12-bit* Bayer	G5-GC31-C4505
●● Nano-5G-M5400	5420 x 5420	On-semi XGS30000	19.3 fps	3.2 µm	66.06 dB	APS-C	8 or 12-bit* Mono	G5-GM31-M5405
●●● Nano-5G-C5400	5420 x 5420	On-semi XGS30000	19.3 fps	3.2 µm	66.0 dB	APS-C	8 or 12-bit* Bayer	G5-GC31-C5405
●● Nano-5G-M8100	8192 x 5420	On-semi XGS45000	19.3 fps	3.2 µm	66.06 dB	Super 35MM Format	8 or 12-bit* Mono	G5-GM31-M8105
●●● Nano-5G-C8100	8192 x 5420	On-semi XGS45000	19.3 fps	3.2 µm	66.0 dB	Super 35MM Format	8 or 12-bit* Bayer	G5-GC31-C8105

*Available with the 12-bit firmware



GENIE NANO FAMILY SPECIFICATIONS (COMMON TO ALL MODELS)

	GENIE NANO-5G (Medium Casing) Applicable to p/n : G5-Gxxx-xxxx0	GENIE NANO-5G (XL Casing) Applicable to p/n : G5-Gxxx-xxxx5
Data Output Transfer	Gigabit Ethernet (1 Gbps, 2.5 Gbps or 5 Gbps — auto-negotiate)	
Exposure Control	Automatic, programmable, or via external trigger	
I/O Ports	2 opto-isolated inputs, 3 opto-isolated outputs	
Image Buffers (On-board memory)	450 MB	
Lens Mount	C-Mount	M42-mount
Size (L x H x W) (C-mount option)	32 mm x 44 mm x 59 mm (no lens adapter) 42 mm x 44 mm x 59 mm (with lens adapter and connectors)	41 mm x 59 mm x 59 mm
Mass	124 g	183 g
Operating Temp	-20 to +65°C (housing temperature)	
Power Supply	10 to 36V or Power Over Ethernet (POE)	
Power Dissipation (model dependent)	9.4 W to 9.6 W	
Data Connector	Standard or screw mount RJ-45	
Power and I/O Connector	SAMTEC TFM-105 type	
Camera Specification	GigE Vision v2.0	
Software Platform	Teledyne DALSA Sopera LT 8.50 for Windows, Teledyne DALSA GigE-V for Linux or 3rd Party GenICam compliant SDK	

RESPONSIVITY GRAPHS

Spectral Sensitivity Characteristics

Excludes lens characteristics and light source characteristics

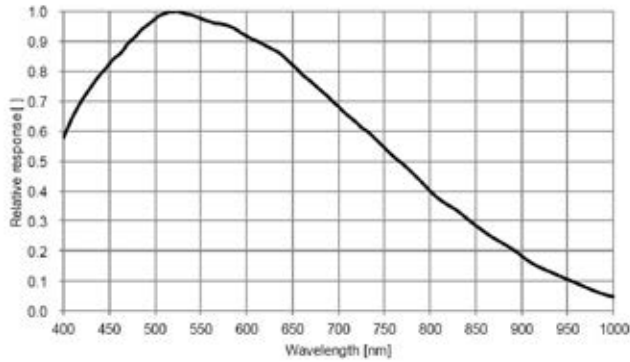

M4060
M4040
M2050
M2450

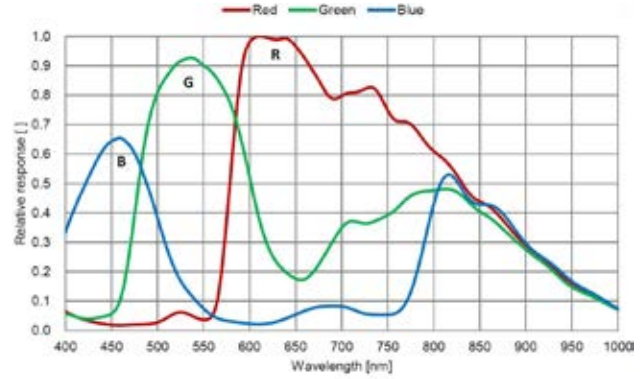

C4060
C4040
C2050
C2450

Models M4500 / M5400 / M8100

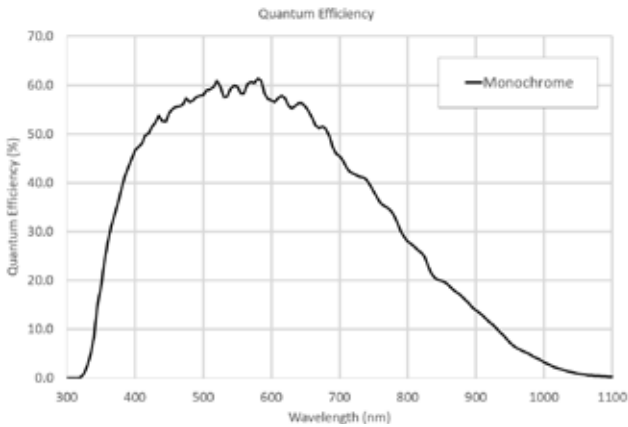

Models C4500 / C5400 / C8100

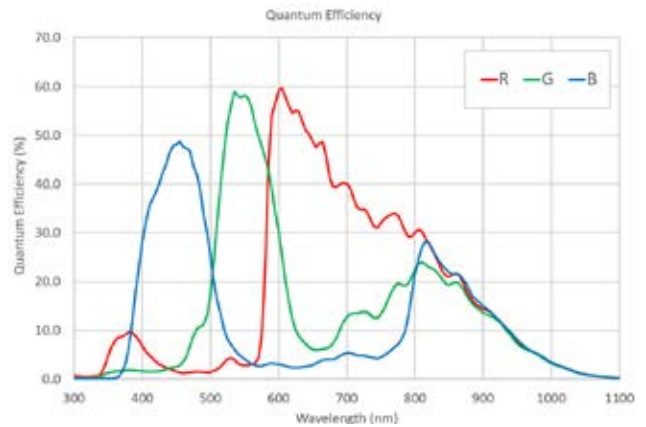

945 East 11th Avenue Tampa, FL 33605

Phone: (813) 984-0125

Contact: Sales@pyramidimaging.com

<https://pyramidimaging.com>

Europe

Krailling, Germany
+49 89-89-54-57-3-80
sales.europe@teledynedalsa.com

Asia Pacific

Tokyo, Japan
+81 3-5960-6353
sales.asia@teledynedalsa.com

Shanghai, China
+86 21-3368-0027
sales.asia@teledynedalsa.com

DRAWING OF P/N : G5-Gxxx-xxxx0

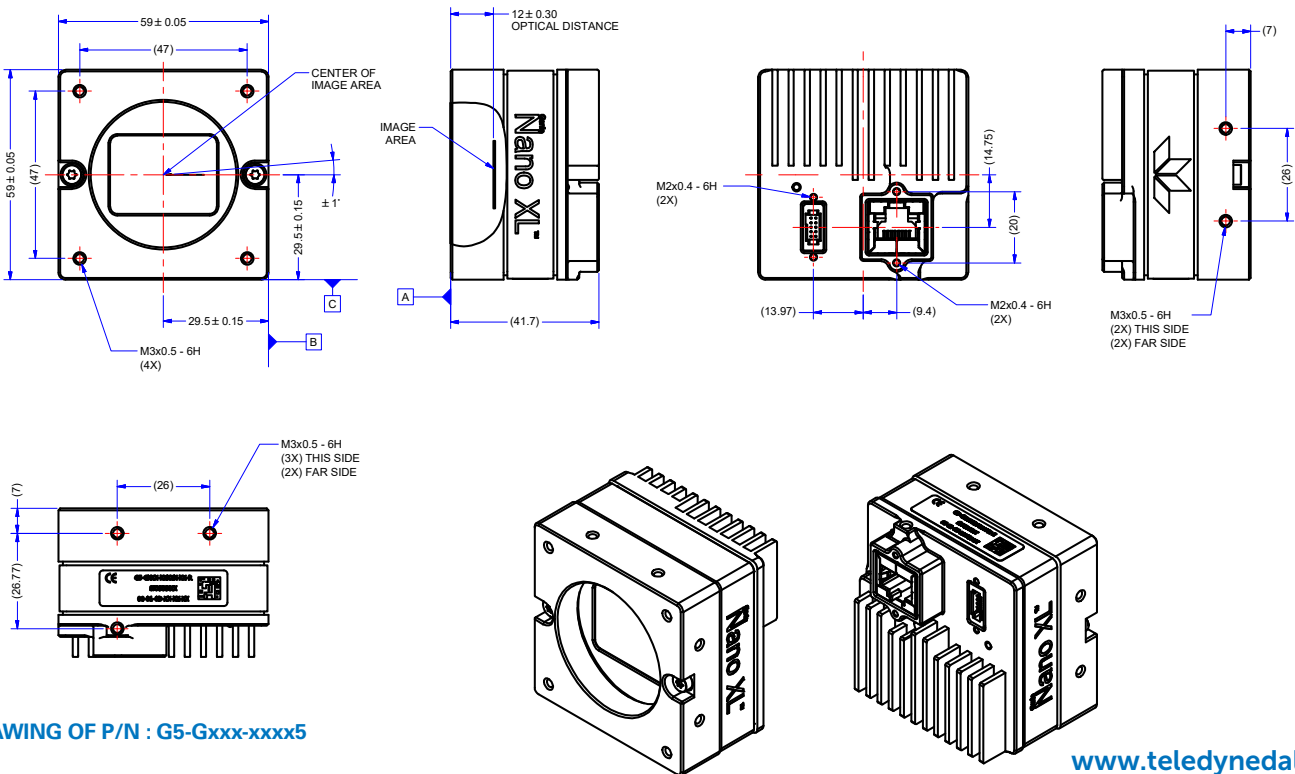
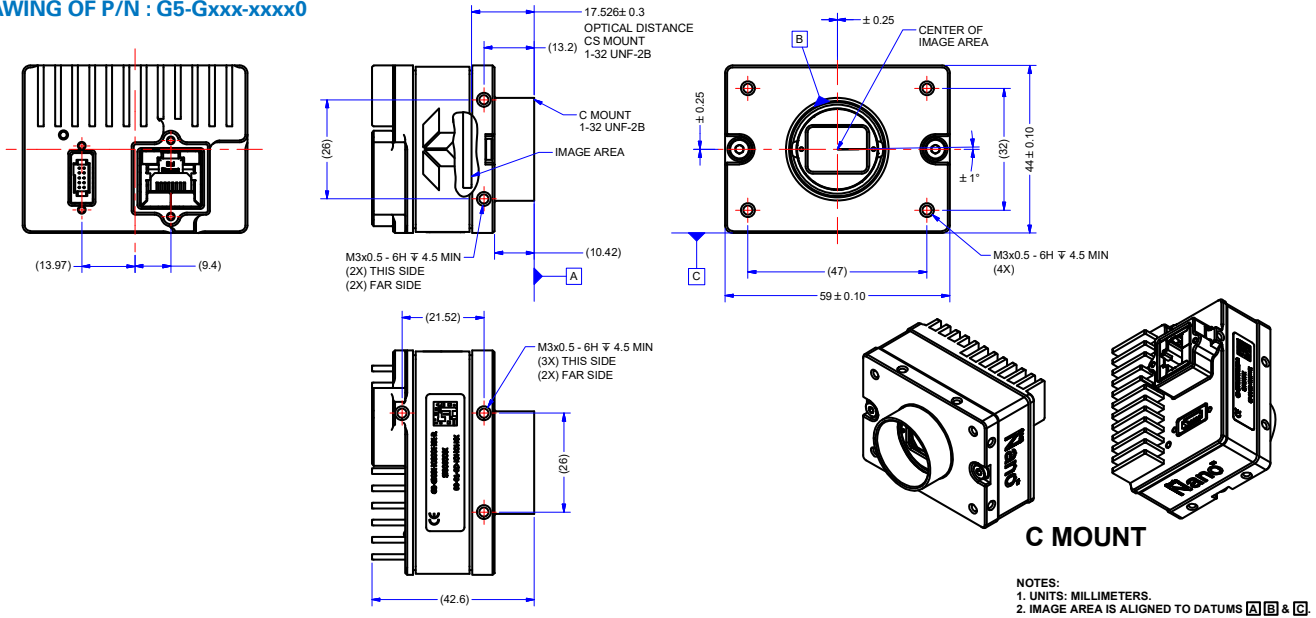

DRAWING OF P/N : G5-Gxxx-xxxx5

Americas

Pyramid Imaging, Inc.
945 East 11th Avenue
Tampa, FL 33605
www.pyramidimaging.com
sales@pyramidimaging.com
+1 813 984 0125

Europe

Krailling, Germany
+49 89-89-54-57-3-80
sales.europe@teledynedalsa.com

Asia Pacific

Tokyo, Japan
+81 3-5960-6353
sales.asia@teledynedalsa.com

Shanghai, China
+86 21-3368-0027
sales.asia@teledynedalsa.com