

945 East 11th Avenue Tampa, FL 33605
 Phone: (813) 984-0125
 Contact: Sales@pyramidimaging.com
<https://pyramidimaging.com>

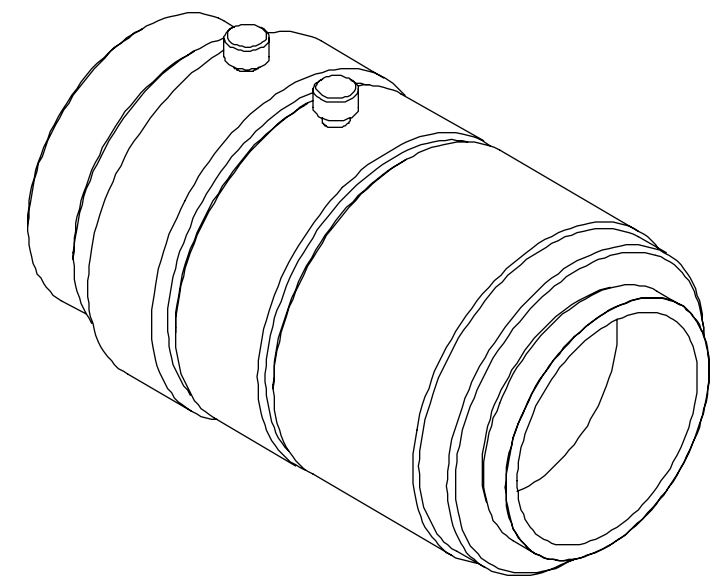

OUTLINE

Lens Specification - NMV - 50M23				
Specification		Value	1/2"	1/3"
Focal Length		f = 50mm		
Max. Diameter (Ratio)		F = 1:2.8 ~ 22		
Element		4 Group 7 Elements		
Picture Size		6.6x8.8mm	4.8x6.4mm	4.8x3.6mm
Angle	Vertical	7.2 deg.	5.2 deg.	3.9 deg.
	Horizontal	9.6 deg.	7.0 deg.	5.2 deg.
	Diagonal	11.9 deg.	8.7 deg.	6.5 deg.
Distortion (TV)		- 0.03%	-	
Shooting Range at Minimum Focus Distance	Vertical	21.9mm	16.0mm	12.0mm
	Horizontal	29.3mm	21.3mm	16.0mm
	Diagonal	36.6mm	26.6mm	20.0mm
Minimum Focus Distance		0.2m		
Flange Back Focus		17.526mm in air		
Back Focus		35.5mm in air		
Filter Screw Size		M27.0x0.5		
Effective Diameter	Front	21.7mm		
	Rear	14.6mm		
Mount		C-Mount		
Exit Pupil		- 63.7mm		
Temperature Range		-10 ~ +45 deg. C		
Strong Temperature Range		-40 ~ +60 deg. C		
Resolution	Center	100 Line/mm		
	Corner	80 Line/mm		
Weight		92g		

UNLESS OTHERWISE SPECIFIED DIMENSIONS ARE IN INCHES AND INCLUDE CHEMICALLY APPLIED OR PLATED FINISHES	THE CONTENTS OF THIS DOCUMENT ARE PROPRIETARY TO NAVITAR. ITS USE IS AUTHORIZED ONLY FOR RESPONDING TO REQUEST FOR QUOTATION OR PERFORMANCE OF WORK FOR NAVITAR		 ROCHESTER, NEW YORK	
	SCALE: 1.5:1			
WEIGHT: See Table	DR: BE		LENS, 50mm FL, f/2.8, 2/3" MEGAPIXEL	
CH:	PROJECT #: E2338		SIZE B	NMV - 50M23 SHEET 1 OF 1
DATE DR: 7/11/2007	DO NOT SCALE DRAWING			