

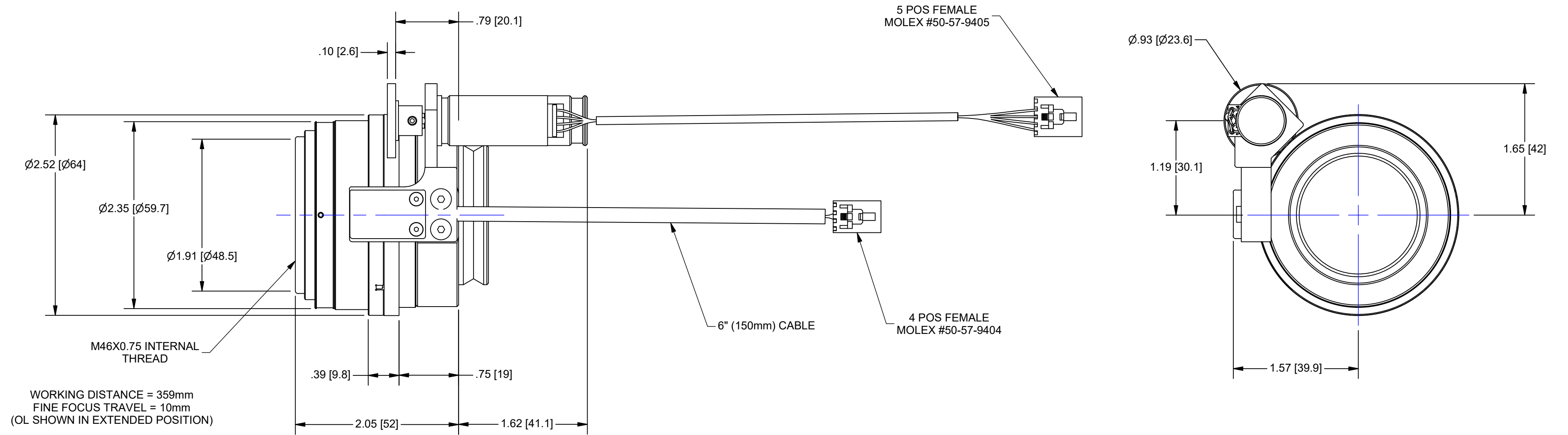

945 East 11th Avenue Tampa, FL 33605
 Phone: (813) 984-0125
 Contact: Sales@pyramidimaging.com
 https://pyramidimaging.com

SCALE 1:1



2φ MOTOR AND HALL EFFECT CABLE INFORMATION:

- FOCUS / HE CABLE LENGTH = 0.15m
- USE NAVITAR #1-40281 (1.8m), 1-40282 (1.2m), 1-40283 (0.6m) TO CONNECT TO NAVITAR 2φ CONTROLLERS (1-40241, 1-40233, 1-40234)

FF MOTOR
 5 POSITION FEMALE
 CONNECTOR
 (MOLEX #50-57-9405)

HE SENSOR
 4 POSITION FEMALE
 CONNECTOR
 (MOLEX #50-57-9404)

2φ FF MOTOR PINOUT
 PIN 1 = MOTOR A+ (GREEN)
 PIN 2 = MOTOR A- (RED)
 PIN 3 = MOTOR B+ (BLACK)
 PIN 4 = MOTOR B- (WHITE)
 PIN 5 = N/C

4 PIN HE SENSOR PINOUT
 PIN 1 = COMMON
 PIN 2 = FAR LIMIT
 PIN 3 = +5VDC
 PIN 4 = NEAR LIMIT

OUTLINE

UNLESS OTHERWISE SPECIFIED DIMENSIONS ARE IN INCHES (MM) AND INCLUDE CHEMICALLY APPLIED OR PLATED FINISHES	PROPRIETARY AND CONFIDENTIAL THE INFORMATION CONTAINED IN THIS DRAWING IS THE SOLE PROPERTY OF NAVITAR. ANY REPRODUCTION IN PART OR AS A WHOLE WITHOUT THE WRITTEN PERMISSION OF NAVITAR IS PROHIBITED.			
SCALE: 2:1				
WEIGHT: 0.73 lbmass	DR BY: BONAFEDE	MTR FF, 2φ, 0.25X LENS ATTACHMENT		
CH BY: J. WILLIAMSON	PROJECT #: E3506			
DATE DR: 9/18/2017	DO NOT SCALE DRAWING	SIZE: C	PART NUMBER: 1-81201M2	REV: A