

SCALE 1 : 1

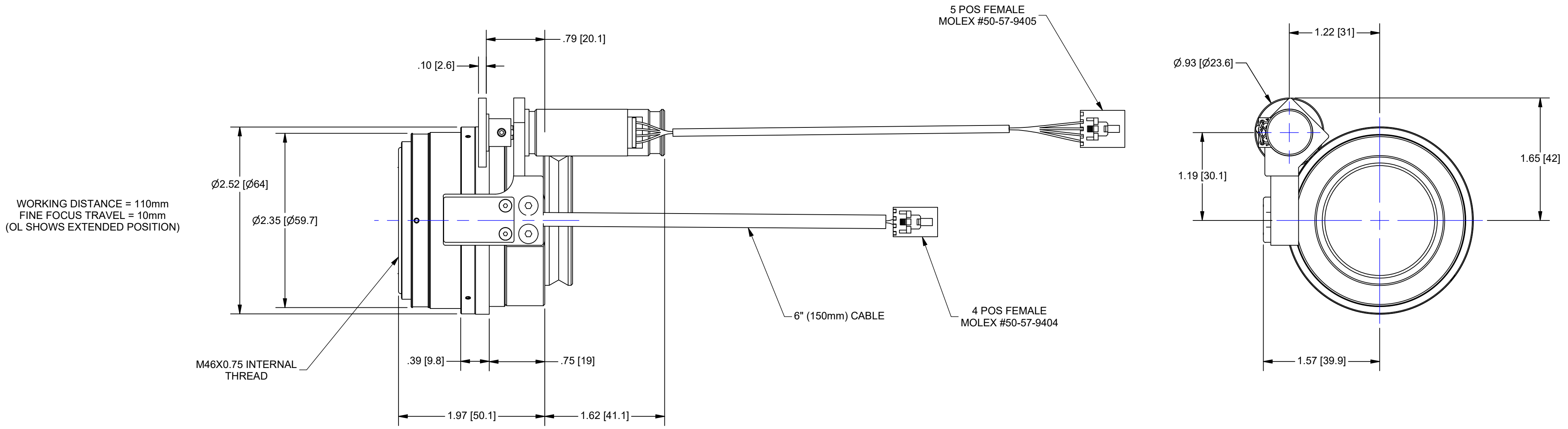

WORKING DISTANCE = 110mm
FINE FOCUS TRAVEL = 10mm
(OL SHOWS EXTENDED POSITION)

2φ MOTOR AND HALL EFFECT CABLE INFORMATION:

- FOCUS / HE CABLE LENGTH = 0.15m
- USE NAVITAR #1-40281 (1.8m), 1-40282 (1.2m), 1-40283 (0.6m) TO CONNECT TO NAVITAR 2φ CONTROLLERS (1-40241, 1-40233, 1-40234)

FF MOTOR
5 POSITION FEMALE
CONNECTOR
(MOLEX #50-57-9405)

HE SENSOR
4 POSITION FEMALE
CONNECTOR
(MOLEX #50-57-9404)

2φ FF MOTOR PINOUT
PIN 1 = MOTOR A+ (GREEN)
PIN 2 = MOTOR A- (RED)
PIN 3 = MOTOR B+ (BLACK)
PIN 4 = MOTOR B- (WHITE)
PIN 5 = N/C

4 PIN HE SENSOR PINOUT
PIN 1 = COMMON
PIN 2 = FAR LIMIT
PIN 3 = +5VDC
PIN 4 = NEAR LIMIT



945 East 11th Avenue Tampa, FL 33605
Phone: (813) 984-0125
Contact: Sales@pyramidimaging.com
<https://pyramidimaging.com>

OUTLINE

UNLESS OTHERWISE SPECIFIED DIMENSIONS ARE IN INCHES (MM) AND INCLUDE CHEMICALLY APPLIED OR PLATED FINISHES	PROPRIETARY AND CONFIDENTIAL	
	THE INFORMATION CONTAINED IN THIS DRAWING IS THE SOLE PROPERTY OF NAVITAR. ANY REPRODUCTION IN PART OR AS A WHOLE WITHOUT THE WRITTEN PERMISSION OF NAVITAR IS PROHIBITED.	
SCALE: 2:1	0.0 inch 1.0	MTR FF, 2φ, 0.75X, LENS ATTACHMENT
WEIGHT: N/A	0.0 mm 25.0	
DR BY: BONAFEDE	DO NOT SCALE DRAWING	SIZE C
CH BY: J. WILLIAMSON		PART NUMBER 1-81203M2
PROJECT #: E3506		REV A
DATE DR: 9/17/2017		