

SCALE 1:1

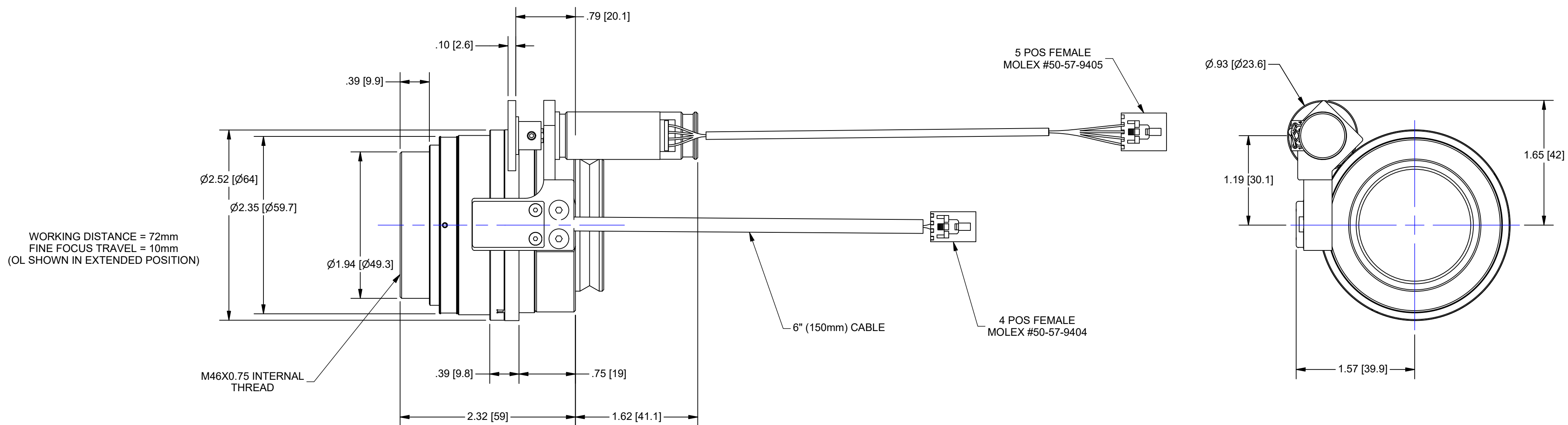

**2φ MOTOR AND HALL EFFECT CABLE INFORMATION:**

- FOCUS / HE CABLE LENGTH = 0.15m
- USE NAVITAR #1-40281 (1.8m), 1-40282 (1.2m), 1-40283 (0.6m) TO CONNECT TO NAVITAR 2φ CONTROLLERS (1-40241, 1-40233, 1-40234)

FF MOTOR  
5 POSITION FEMALE  
CONNECTOR  
(MOLEX #50-57-9405)

HE SENSOR  
4 POSITION FEMALE  
CONNECTOR  
(MOLEX #50-57-9404)

**2φ FF MOTOR PINOUT**  
PIN 1 = MOTOR A+ (GREEN)  
PIN 2 = MOTOR A- (RED)  
PIN 3 = MOTOR B+ (BLACK)  
PIN 4 = MOTOR B- (WHITE)  
PIN 5 = N/C

**4 PIN HE SENSOR PINOUT**  
PIN 1 = COMMON  
PIN 2 = FAR LIMIT  
PIN 3 = +5VDC  
PIN 4 = NEAR LIMIT



945 East 11<sup>th</sup> Avenue Tampa, FL 33605  
Phone: (813) 984-0125  
Contact: Sales@pyramidimaging.com  
<https://pyramidimaging.com>

**OUTLINE**



MTR FF, 2φ, 1.25X LENS  
ATTACHMENT

UNLESS OTHERWISE SPECIFIED DIMENSIONS ARE IN INCHES (MM) AND INCLUDE CHEMICALLY APPLIED OR PLATED FINISHES		PROPRIETARY AND CONFIDENTIAL THE INFORMATION CONTAINED IN THIS DRAWING IS THE SOLE PROPERTY OF NAVITAR. ANY REPRODUCTION IN PART OR AS A WHOLE WITHOUT THE WRITTEN PERMISSION OF NAVITAR IS PROHIBITED.		PART NUMBER	
SCALE:	2:1	0.0 inch 1.0 0.0 mm 25.0		1-81205M2	
WEIGHT:	0.89 lbmass	DO NOT SCALE DRAWING		SIZE	C
DR BY:	BONAFEDE	⊕		REV	A
CH BY:	J. WILLIAMSON				
PROJECT #:	E3506				
DATE DR:	9/19/2017				