

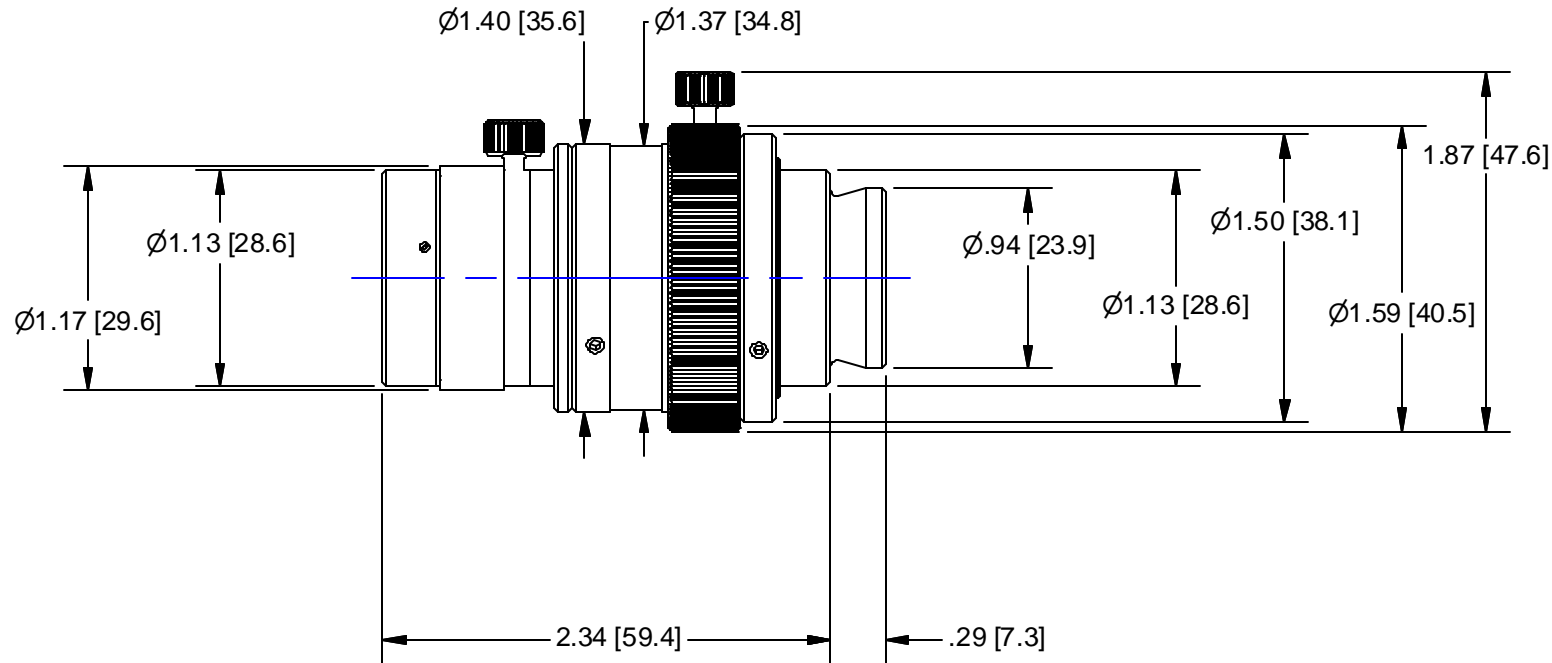

945 East 11th Avenue Tampa, FL 33605
 Phone: (813) 984-0125
 Contact: Sales@pyramidimaging.com
 https://pyramidimaging.com

REV	CHANGE RECORD AND DATE	CH
-----	------------------------	----



OUTLINE

USED ON:

MATERIAL:

FINISH:

ANODIZE, DYE BLACK

CHAMFER ALL THREADS 30° TO ROOT DIAMETER

UNLESS OTHERWISE SPECIFIED DIMENSIONS ARE IN INCHES AND INCLUDE CHEMICALLY APPLIED OR PLATED FINISHES

TOLERANCES AS FOLLOWS
 DEC. .XXX ± .005
 DEC. .XX ± .010
 FRACT. ± 1/64
 ANGLES ± 30°
 CONCENTRICITY .003 TIR
 BREAK ALL SHARP EDGES .005 MIN. .010 MAX.
 MAX. SURF. ROUGHNESS: $\sqrt{32}$

SCALE: 1:1

DR: JK

CH: PB

APP: PB

DATE DR: 2/5/2003

DO NOT SCALE DRAWING

P/N SUFFIX DEFINITION

- 1 CONVERSION COATING
- 2 PAINTING
- 3 MARKING
- R REWORK

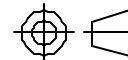
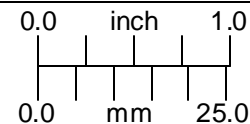

PRECISE EYE w/3mm F.F. & APERTURE

SIZE	1-62473	REV
A	SHEET 1 OF 1	A