



945 East 11<sup>th</sup> Avenue Tampa, FL 33605

Phone: (813) 984-0125

Contact: Sales@ pyramidimaging.com

https://pyramidimaging.com

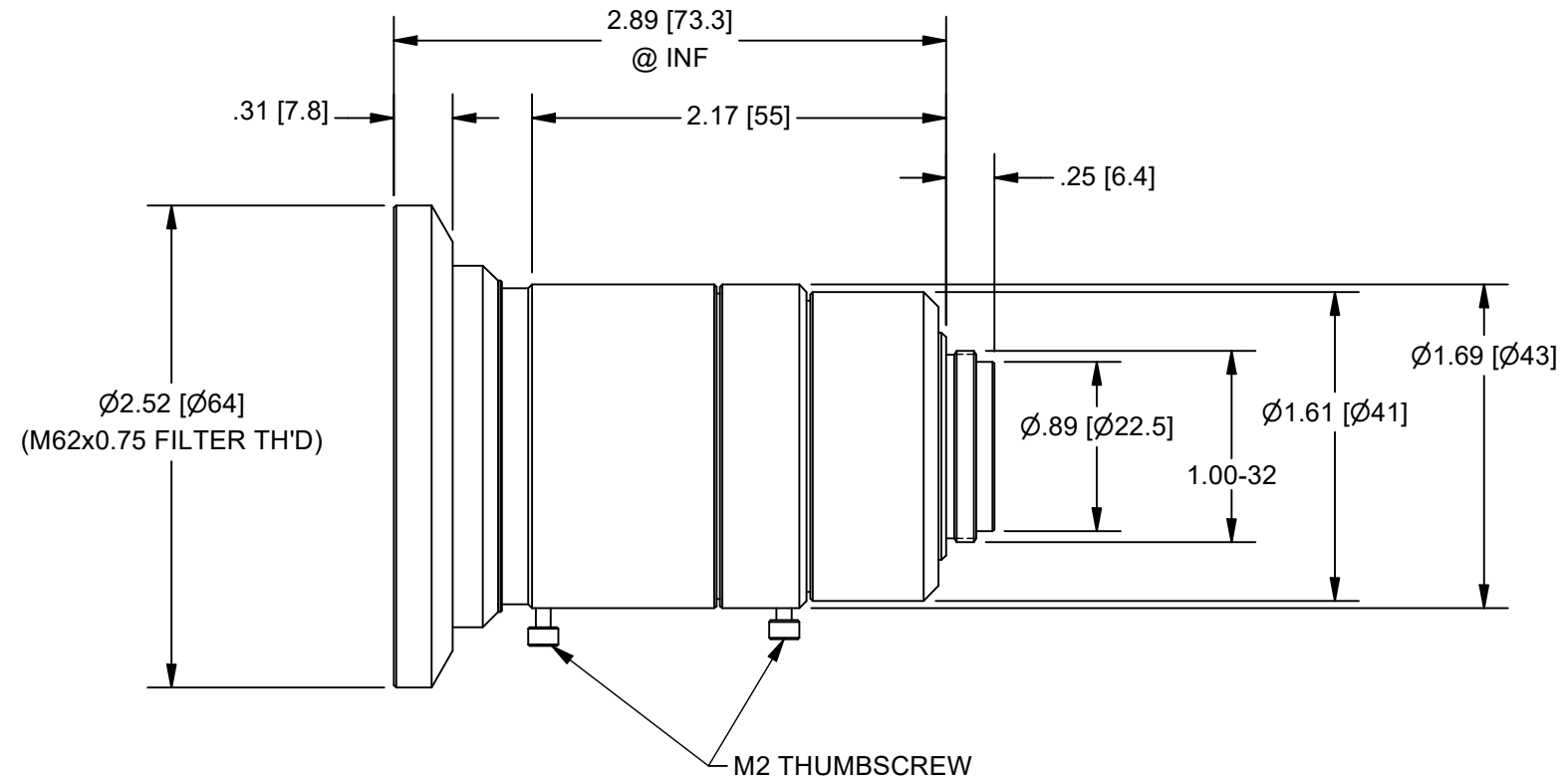

Lens Specifications - 1.1" 8.5mm F/2.5, 24MP

Specifications	1.1"	1"	2/3"
Focal Length	f =8.5mm		
Maximum diameter (Ratio)	F = 2.5 - 16		
Picture Size	10.6 x 14.1 mm	9.6 x 12.8 mm	6.6 x 8.8 mm
Angle			
- Vertical	63.8 deg	58.8 deg	42.1 deg
- Horizontal	79.2 deg	73.9 deg	54.5 deg
- Diagonal	91.2 deg	86.1 deg	65.8 deg
Distortion	0.55%	0.13%	-0.4%
FOV			
- Vertical	138mm	125mm	86mm
(@MOD) - Horizontal	184mm	167mm	115mm
- Diagonal	228mm	208mm	144mm
Minimum Focus Distance	0.1m		
Flange Focus	17.526mm in air		
Back Focus	10.9mm in air		
Filter Screw Size	M62x0.75		
Clear Aperture Front / Rear	Ø40mm / Ø18.0mm		
Mount	C-Mount		
Exit Pupil	-125.7mm		
Temperature Range	- 10 ~ + 50 deg. C		
Storage Temperature Range	- 20 ~ + 60 deg. C		
Resolution Center / Corner	200lp/mm / 100lp/mm		
Weight	230g		

# OUTLINE



UNLESS OTHERWISE SPECIFIED DIMENSIONS ARE IN INCHES [MM] AND INCLUDE CHEMICALLY APPLIED OR PLATED FINISHES

**PROPRIETARY AND CONFIDENTIAL**  
THE INFORMATION CONTAINED IN THIS DRAWING IS THE SOLE PROPERTY OF NAVITAR. ANY REPRODUCTION IN PART OR AS A WHOLE WITHOUT THE WRITTEN PERMISSION OF NAVITAR IS PROHIBITED.

SCALE: 1:1

WEIGHT: SEE TABLE

DR BY: PB

CH BY: J. WILLIAMSON

PROJECT #:

DATE DR: 11/9/2018

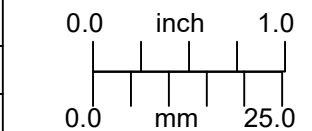

DO NOT SCALE DRAWING



LENS, 8.5mm, F/2.5, 1.1", 24MP C-MNT

SIZE	PART NUMBER	REV
<b>B</b>	<b>NMV-8M1.1</b>	<b>C</b>