

THUMB SCREW
M2

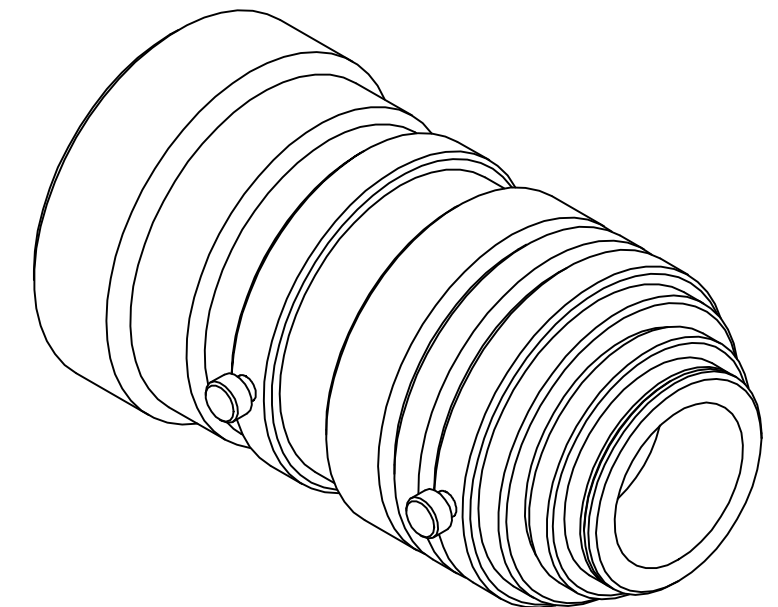

OUTLINE

Lens Specifications - NMV - 75			
Specifications	2/3"	1/1.8"	1/2"
Focal Length	f = 75mm		
Maximum diameter (Ratio)	F = 1:2.5 ~ 22		
Picture Size	6.6 x 8.8mm		
Angle - Vertical	5.0 deg.	4.1 deg.	3.7 deg.
Horizontal	6.7 deg.	5.5 deg.	4.9 deg.
Diagonal	8.3 deg.	6.8 deg.	6.0 deg.
Distortion	-0.1%		
Shooting Range - Vertical	99.6mm	81.5mm	72.5mm
At Minimum - Horizontal	132.6mm	108.6mm	96.6mm
Focus Distance - Diagonal	165.6mm	135.7mm	120.7mm
Minimum Focus Distance	1.2m		
Flange Back	17.526mm in air		
Back Focus	18.0mm in air		
Filter Screw Size	M34 X 0.5		
Effective Diameter - Front	30.2mm dia.		
- Rear	12.4mm dia.		
Mount	C-Mount		
Exit Pupil	-32.9mm dia.		
Temperature Range	- 10 ~ + 50 deg. C		
Strong Temperature Range	- 40 ~ + 60 deg. C		
Resolution - Center	100 Line/mm		
- Corner	80 Line/mm		
Weight	105g		



UNLESS OTHERWISE SPECIFIED DIMENSIONS ARE IN INCHES AND INCLUDE CHEMICALLY APPLIED OR PLATED FINISHES	THE CONTENTS OF THIS DOCUMENT ARE PROPRIETARY TO NAVITAR, ITS USE IS AUTHORIZED ONLY FOR RESPONDING TO REQUEST FOR QUOTATION OR PERFORMANCE OF WORK FOR NAVITAR		 ROCHESTER, NEW YORK
	SCALE: 1.5:1	WEIGHT: 105 g	
CH: JD	PROJECT #: E2338	DATE DR: 7/13/2007	 DO NOT SCALE DRAWING
LENS, 75.0mm FL, , 2/3", f/2.5			SIZE B NMV - 75M23 SHEET 1 OF 1
			REV B