

Lens Specifications - NMV-100M23			
Specification	2/3"	1/1.8"	1/2"
Focal Length	f = 100 mm		
Maximum diameter (Ratio)	F = 1:2.8 ~ 32		
Picture Size	6.6x8.8mm		
Angle - Vertical	3.8 deg.	3.1 deg.	2.8 deg.
Horizontal	5.0 deg.	4.1 deg.	3.7 deg.
Diagonal	6.3 deg.	5.1 deg.	4.6 deg.
Distortion	-0.05%		
Shooting Range - Vertical	126.6mm	103.5mm	92.0mm
At Minimum - Horizontal	168.8mm	138.1mm	122.7mm
Focus Distance - Diagonal	211.1mm	172.6mm	153.4mm
Minimum Focus Distance	2.0m		
Flange Back	17.526mm in air		
Back Focus	19.0mm in air		
Filter Screw Size	M40.5x0.5		
Effective Diameter - Front	35.2mm dia.		
- Rear	11.2mm dia.		
Mount	C-Mount		
Exit Pupil	-31.0mm dia.		
Temperature Range	- 10 ~ + 50 deg. C		
Strong Temperature Range	- 40 ~ + 60 deg. C		
Resolution - Center	100 Line/mm		
- Corner	80Line/mm		
Weight	145 g		

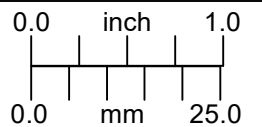

945 East 11<sup>th</sup> Avenue Tampa, FL 33605  
 Phone: (813) 984-0125  
 Contact: Sales@pyramidimaging.com  
<https://pyramidimaging.com>

## OUTLINE

UNLESS OTHERWISE SPECIFIED DIMENSIONS ARE IN INCHES AND INCLUDE CHEMICALLY APPLIED OR PLATED FINISHES	THE CONTENTS OF THIS DOCUMENT ARE PROPRIETARY TO NAVITAR. ITS USE IS AUTHORIZED ONLY FOR RESPONDING TO REQUEST FOR QUOTATION OR PERFORMANCE OF WORK FOR NAVITAR		 ROCHESTER, NEW YORK
	SCALE: 1.5:1	WEIGHT: 145 g	
CH:	PROJECT #:	DATE DR: 4/8/2021	 DO NOT SCALE DRAWING
SIZE <b>B</b>	<b>NMV-100M23</b> SHEET 1 OF 1		LENS, 100mm, F/2.8, 2/3", MP REV