

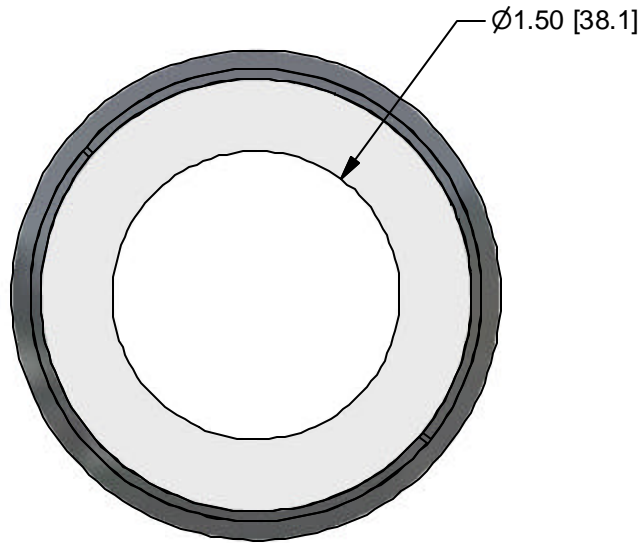

Pyramid Imaging

Tampa, FL
 sales@pyramidimaging.com
 www.pyramidimaging.com
 813-786-3785



OUTLINE

USED ON:

MATERIAL:

FINISH:

CHAMFER ALL THREADS 30° TO ROOT DIAMETER

UNLESS OTHERWISE SPECIFIED
 DIMENSIONS ARE IN INCHES AND INCLUDE
 CHEMICALLY APPLIED OR PLATED FINISHES

TOLERANCES AS FOLLOWS
 DEC. .XXX ± .005
 DEC. .XX ± .010
 FRACT. ± 1/64
 ANGLES ± 30°
 CONCENTRICITY .003 TIR
 BREAK ALL SHARP EDGES
 .005 MIN. .010 MAX.
 MAX. SURF. ROUGHNESS: $\sqrt{32}$

SCALE: 1:1
 DR: DJM
 CH: PB
 APP: PB
 DATE DR: 11/15/2002
 DO NOT SCALE DRAWING

P/N SUFFIX DEFINITION

- 1 CONVERSION COATING
- 2 PAINTING
- 3 MARKING
- R REWORK

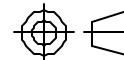
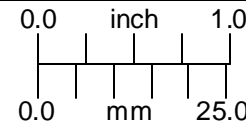

NAVITAR
 ROCHESTER, NEW YORK

100mm W.D. FRESNEL LENS
 ATTACHMENT

SIZE	1-62357_OL	REV
A	SHEET 1 OF 1	A