

Refer to our website for product details.

CCS PD3

Search



You can also use your smartphone or cell phone.

For quick access.

Select Digital Control Units matching your network

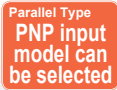

AC Input Types

DC Input Types



The supplied AC cord is for use with 100 to 120 VAC. If you want to use the Control Unit with 200 to 240 VAC, you must procure another appropriate AC power cord.

For information on change in model names, refer to P.329.

Features

- Each single unit is compatible with continuous, ON/OFF and strobe lighting. (Spot Light HLV series cannot emit strobe.)
- Digital display enables set values to be easily checked. Spot Light HLV3 series Product Page ▶ P. 187
Spot Light HLV2 series Product Page ▶ P. 193
- 256 stage dimmer settings.
- Select from 3 types of external control.
- AC input types and DC input types available.
- DIN rail installation is standard.
- Select from 3 channel, 4 channel or 8 channel models.
- There are four types of capacity: 3 channel/28 W^{*1}, 3 channel/48 W^{*2}, 4 channel/46 W^{*3}, and 8 channel/95 W^{*3}.
*1: Can be connected only with 24 V Light. *2: Lineup includes only DC-input Control Units.
 *3: Can be connected with both 24 V Light and Spot Light HLV series.

A Wide Ranging Lineup is Available and Custom Orders are Accepted

- The parallel type has the fastest switching for settings. Perform high-speed control through batch transmission. (External trigger signal input is available as an NPN input model (standard) or PNP input model (custom order product: PD3-PNP)) See ▶ P.325 for details
- Ethernet types support standard TCP/IP and UDP/IP protocols. (Models with keep-alive functions (custom order: PD3-EIK) are available) See ▶ P.326 for details
Keep-alive functions monitor the validity of the connection of the machine to the network, wherein to prevent the connection from dropping, a signal is periodically sent between machines.
- The EIA-485 type can individually manage units using multi-drop wiring. Can manage up to 4 units. See ▶ P.327 for details
- PWM frequency is available in 125 kHz (standard) and 500 kHz (custom order: PD3-500). See ▶ P.326 for details

PD3
PD2
PSB
POD
PTU2
PF
CN-EPOE
CN-4024-2-EIPT
PB-2430-1
CC-ST-1024
PJ2
PJ
CC-PJ-0707
PSCC
PSB4
PSB3-30024
Band-Pass Filters
Lens Filters
Diffusion Plates
Polarizing Plates
Light Control Films
Fixtures, etc.
Brackets
SM/EL Cables

Example System Configuration

Example:
External control device — External control cables — Control Unit — Extension cables — LED Light

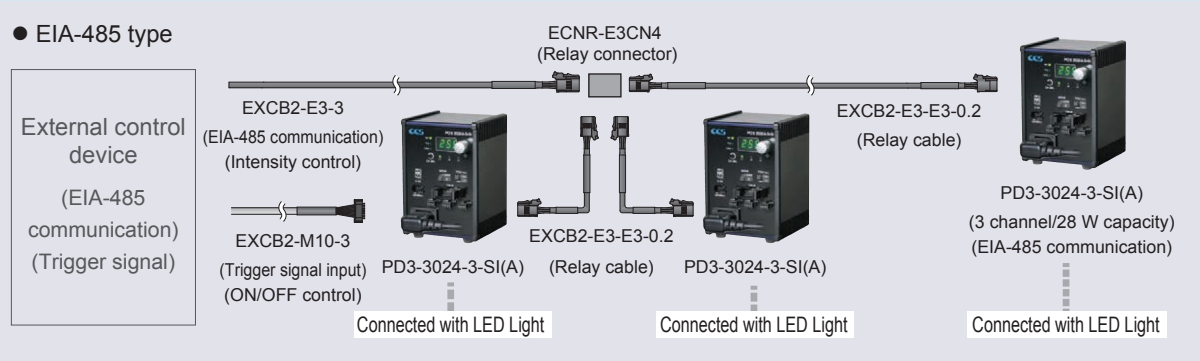
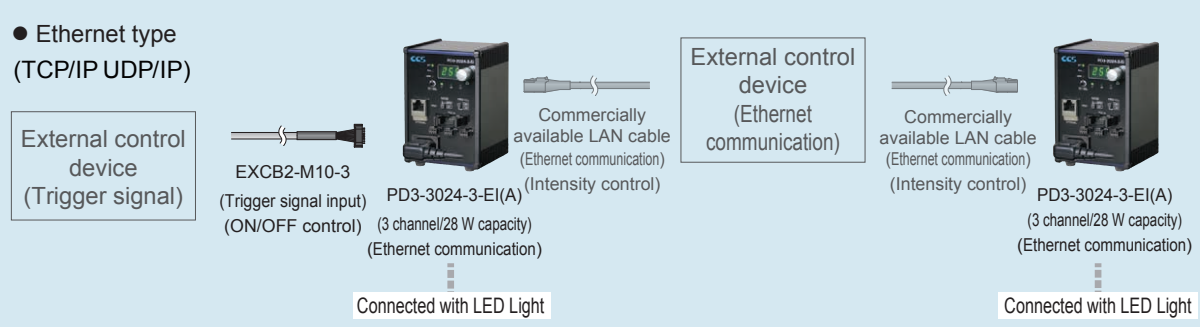
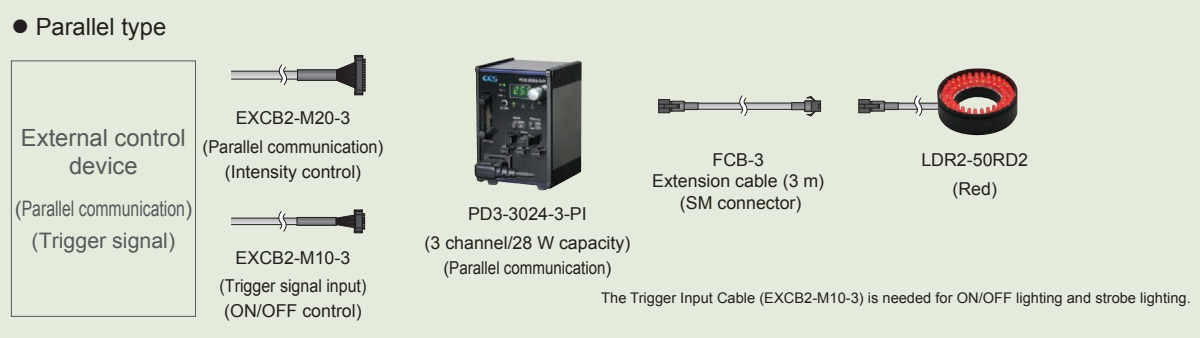

Fixture Connection Example

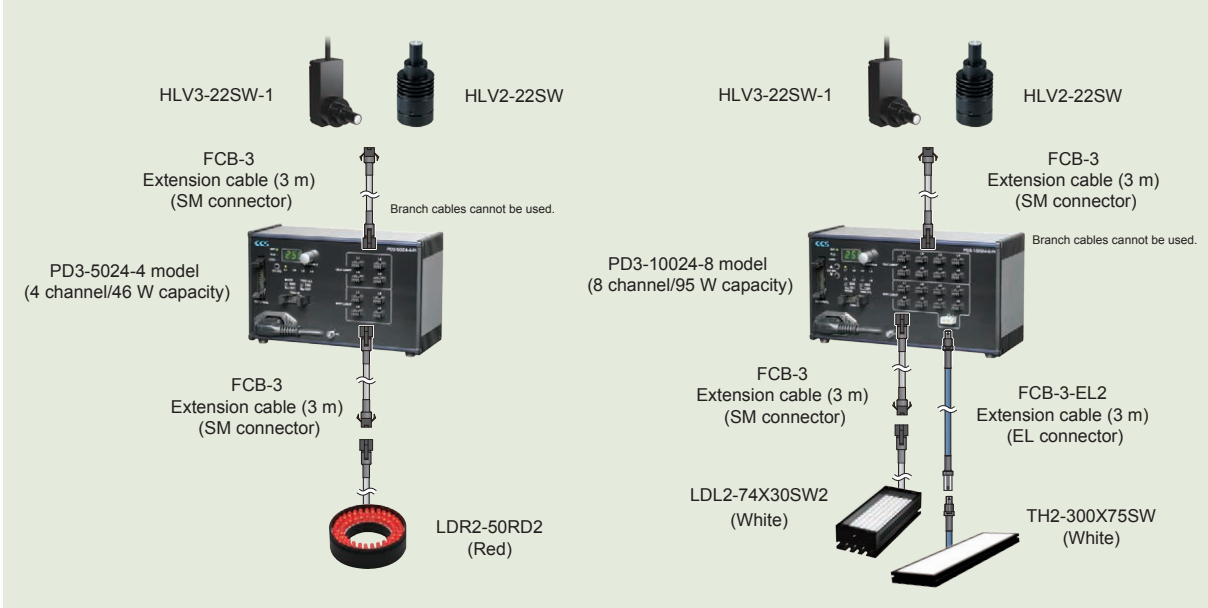

You can inquire using our website.

- Sample Testing
- Light Unit Selection
- Free Product Trial
- Custom Orders
- Product Details
- Pricing/Quotation
- Discontinued Products

Inquire on our website here. <https://www.ccs-grp.com/contact/>

PD3 Series



Refer to our website for product details.

CCS PD3



You can also use your smartphone or cell phone.

For quick access.

Common Specifications: Parallel Types

External trigger signal input is also available as a PNP input (custom order).

Model	NPN Input Model	PD3-3024-3-PI	PD3-5024-4-PI(A)	PD3-10024-8-PI	PD3-3024-3-PT	PD3-5024-3-PT	PD3-5024-4-PT(A)
	PNP Input Model	PD3-3024-3-PI-PNP	PD3-5024-4-PI-PNP(A)	PD3-10024-8-PI-PNP	PD3-3024-3-PT-PNP	PD3-5024-3-PT-PNP	PD3-5024-4-PT-PNP(A)
Input voltage (rated)	100 to 240 VAC (+10% -15%)			24 VDC (21.6 to 26.4 V)			
Lighting method	Continuous / Strobe lighting (no overdrive)						
Drive method	Constant-voltage system	24 V LIGHT: Constant-voltage system HLV LIGHT: Constant-current system		Constant-voltage system		24 V LIGHT: Constant-voltage system HLV LIGHT: Constant-current system	
Intensity control method	PWM control and lighting time control	24 V LIGHT: PWM control and lighting time control HLV LIGHT: Variable-current control		PWM control and lighting time control		24 V LIGHT: PWM control and lighting time control HLV LIGHT: Variable-current control	
No. of channels	3 channels	4 channels	8 channels	3 channels		4 channels	
Applicable Light Unit (rated)	Light Units with 24 VDC input Total for 3 channels: 28 W	Light Units with 24 VDC input, HLV series (Spot Light) Total for 4 channels: 46 W	Light Units with 24 VDC input, HLV series (Spot Light) Total for 8 channels: 96 W (EL connector: one 95 W connector) (When using EL connector: L1 (CH1))	Light Units with 24 VDC input Total for 3 channels: 28 W	Light Units with 24 VDC input Total for 3 channels: 48 W	Light Units with 24 VDC input, HLV series (Spot Light) Total for 4 channels: 46 W	
PWM frequency	125 kHz						
Error detection display	"OCP" displayed on front digital display: Overcurrent error	"OCP" displayed on front digital display: Overcurrent error "EFN" display: Fan stop error "EID" display: ID error (HLV series only)		"OCP" displayed on front digital display: Overcurrent error		"OCP" displayed on front digital display: Overcurrent error "EFN" display: Fan stop error "EID" display: ID error (HLV series only)	
Overcurrent protection	Operates at 107% of the output current. Reset by pressing and holding the setting switch for 1 sec., or turning the power off and then on again. <small>Do not create an intentional short circuit between the positive (+) and negative (-) outputs.</small>						
Power consumption (typ.)	78 VA	70 VA	130 VA	32 W	-		52 W
Frequency	50/60 Hz						
Output voltage (rated)	24 VDC						
Intensity setting	Manual: 256-step using the front setting switch External: 8-bit input (B0 to B7), write pulse (BRTWR), and channel selection (CHSEL0 to CHSEL2)						
ON/OFF setting	External trigger input Manual: 11-step using the front setting switch						
Lighting mode setting	External: 4-bit input (M0 to M3), write pulse (TRGWR), and channel selection (CHSEL0 to CHSEL2)						
Error detection output	External control connector 19(OC)-20(OE) pin with transistor output When normal: Non-conducting, With overcurrent output detected: Conducting						
External control connector	Trigger input: MIL connector, 10-pin Intensity/Lighting mode setting: MIL connector, 20-pin						
Operating temperature and humidity	Temperature: 0 to 40°C, Humidity: 20 to 85%RH (with no condensation)						
Storage temperature and humidity	Temperature: -20 to 60°C, Humidity: 20 to 85%RH (with no condensation)						
Cooling method	Natural air cooling	Forced air cooling		Natural air cooling		Forced air cooling	
CE marking	Safety standard: Conforms to EN61010-1, EMC standard: Conforms to EN61326-1 Class A			EMC standard: Conforms to EN61326-1 Class A			
Material/Surface processing	Material: aluminum and resin, Surface processing: blue alumite						
Weight	600 g max.	1,200 g max.	1,500 g max.	400 g max.		850 g max.	
Accessories	3-prong AC cord with ground terminal (2 m) x 1, Instruction Guide x 1, Base Brackets x 1 set (PD3-5024-4-PI(A)/PI-PNP(A), PD3-10024-8-PI-PNP)			Instruction Guide x 1, Base Brackets x 1 set (PD3-5024-4-PT(A)/PT-PNP(A))			

Connection Example

Refer to the instruction guide for more information.

External Trigger Signal Connection Example

NPN Input Model

Sink Type (NPN)

External Circuit Side

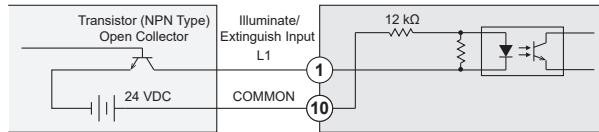

External Signal Connection Example (Parallel Type)

Sink Type (NPN)

External Circuit Side

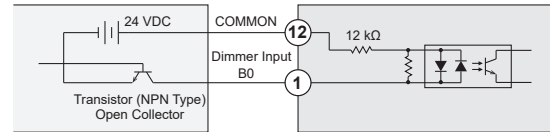

PNP Input Model

Source Type (PNP)

External Circuit Side

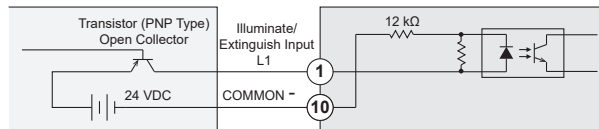

Source Type (PNP)

External Circuit Side

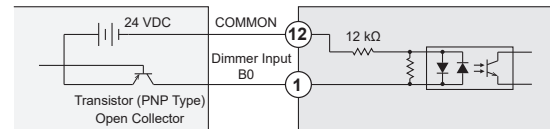

Connection Specifications (Per 1 Terminal)			
Rated Input Voltage	Max. Input Voltage	Photocoupler ON Voltage/ON Current	Photocoupler OFF Voltage/OFF Current
24 VDC	26.4 VDC	14.4 VDC or more/1 mA or more	5 VDC or less/0.4 mA or less

Trigger Principle Setting Switch	Input Signal	Photocoupler	ON/OFF Mode	Strobe Mode
HIGH	HIGH	OFF	LED ON	LED ON for Set Time
	LOW	ON	LED OFF	No Change
LOW	HIGH	OFF	LED OFF	No Change
	LOW	ON	LED OFF	LED ON for Set Time

Connection Specifications (Per 1 Terminal)			
Rated Input Voltage	Max. Input Voltage	Photocoupler ON Voltage/ON Current	Photocoupler OFF Voltage/OFF Current
24 VDC	26.4 VDC	14.4 VDC or more/1 mA or more	5 VDC or less/0.4 mA or less

	Input Signal	Photocoupler	Data
Sink Type	HIGH	OFF	1
	LOW	ON	0
Source Type	HIGH	ON	0
	LOW	OFF	1

- PD3
- PD2
- PSB
- POD
- PTU2
- PF
- CN-EPOE
- CN-4024-2-EIPT
- PB-2430-1
- CC-ST-1024
- PJ2
- PJ
- CC-PJ-0707
- PSCC
- PSB4
- PSB3-30024
- Band-Pass Filters
- Lens Filters
- Diffusion Plates
- Polarizing Plates
- Light Control Films
- Fixtures, etc.
- Brackets
- SM/EL Cables

Common Specifications: Ethernet Type

External trigger signal input PNP input model (custom order) and model with keep alive function (custom order) are also available.

Model name	-	PD3-3024-3-EI(A)	PD3-5024-4-EI(A)	PD3-10024-8-EI(A)	PD3-3024-3-ET(A)	PD3-5024-3-ET(A)	PD3-5024-4-ET(A)
PNP Input Model		PD3-3024-3-EI-PNP(A)	PD3-5024-4-EI-PNP(A)	PD3-10024-8-EI-PNP(A)	PD3-3024-3-ET-PNP(A)	PD3-5024-3-ET-PNP(A)	-
With Keep-Alive Function		PD3-3024-3-EIK	PD3-5024-4-EIK	PD3-10024-8-EIK	PD3-3024-3-ETK	PD3-5024-3-ETK	PD3-5024-4-ETK
Input voltage (rated)		100 to 240 VAC (+10% -15%)			24 VDC (21.6 to 26.4 V)		
Lighting method		Continuous / Strobe lighting (no overdrive)					
Drive method	Constant-voltage system	24 V LIGHT: Constant-voltage system HLV LIGHT: Constant-current system		Constant-voltage system		24 V LIGHT: Constant-voltage system HLV LIGHT: Constant-current system	
Intensity control method	PWM control and lighting time control	24 V LIGHT: PWM control and lighting time control HLV LIGHT: Variable-current control		PWM control and lighting time control		24 V LIGHT: PWM control and lighting time control HLV LIGHT: Variable-current control	
No. of channels	3 channels	4 channels	8 channels	3 channels		4 channels	
Applicable Light Unit (rated)	Light Units with 24 VDC input Total for 3 channels: 28 W	Light Units with 24 VDC input, HLV series (Spot Light) Total for 4 channels: 46 W	Light Units with 24 VDC input, HLV series (Spot Light) Total for 8 channels: 95 W (EL connector: one 95 W connector) *When using EL connector: L1 (CH1)	Light Units with 24 VDC input Total for 3 channels: 28 W	Light Units with 24 VDC input Total for 3 channels: 48 W	Light Units with 24 VDC input, HLV series (Spot Light) Total for 4 channels: 46 W	
PWM frequency	125 kHz						
Error detection display	"OCP" displayed on front digital display: Overcurrent error	"OCP" displayed on front digital display: Overcurrent error "EFN" display: Fan stop error "EID" display: ID error (HLV series only)		"OCP" displayed on front digital display: Overcurrent error		"OCP" displayed on front digital display: Overcurrent error "EFN" display: Fan stop error "EID" display: ID error (HLV series only)	
Overcurrent protection	Operates at 107% of the output current. Reset by pressing and holding the setting switch for 1 sec., or turning the power off and then on again. Do not create an intentional short circuit between the positive (+) and negative (-) outputs.						
Power consumption (typ.)	78 VA	70 VA	130 VA	32 W	52 W		
Frequency	50/60 Hz			-			
Output voltage (rated)	24 VDC						
Intensity setting	Manual: 256-step using the front setting switch						
	External: Command input via TCP/IP or UDP/IP communication						
ON/OFF setting	External trigger input or command input via TCP/IP or UDP/IP communication						
Lighting mode setting	Manual: 11-step using the front setting switch						
	External: Command input via TCP/IP or UDP/IP communication						
Error detection output	Command sent when overcurrent output is detected.						
External control connector	Trigger input: MIL connector, 10-pin						
	Intensity/Lighting mode setting: RJ-45 connector						
Operating temperature and humidity	Temperature: 0 to 40°C, Humidity: 20 to 85% RH (with no condensation)						
Storage temperature and humidity	Temperature: -20 to 60°C, Humidity: 20 to 85% RH (with no condensation)						
Cooling method	Natural air cooling	Forced air cooling		Natural air cooling		Forced air cooling	
CE marking	Safety standard: Conforms to EN61010-1, EMC standard: Conforms to EN61326-1 Class A			EMC standard: Conforms to EN61326-1 Class A			
Material/Surface processing	Material: Aluminum and resin, Surface processing: Blue alumite						
Weight	600 g max.	1,200 g max.	1,500 g max.	400 g max.		850 g max.	
Accessories	3-prong AC cord with ground terminal (2 m) x 1, Instruction Guide x 1, Base Brackets x 1 set (PD3-5024-4-EI(A)/EI-PNP(A)-EIK, PD3-10024-8-EI(A)/EI-PNP(A)-EIK)			Instruction Guide x 1, Base Brackets x 1 set (PD3-5024-4-ET(A)/ET-PNP(A)-ETK)			

Keep-alive functions monitor the validity of the connection of the machine to the network, wherein to prevent the connection from dropping, a signal is periodically sent between machines.

Lineup of Models with 500 kHz PWM Frequency <Custom Order Products>

When selecting a digital power supply, consider using the higher frequency type. Power supplies with a PWM frequency of 500 kHz can be made to order. Contact our local sales office for details.

Introducing High Frequency Power Supplies (Custom Order)

PD3-10024-8 Series

- PWM Dimmer Control (500 kHz)
- 95 W Capacity (EL Connector: 1 Channel)
- AC Input
- 3 types of external control
 - Parallel communication
 - Ethernet communication
 - EIA-485 communication



PD3-10024-8-SI-500
(EIA-485 type)



PD3-10024-8-PI-500
(Parallel type)



PD3-10024-8-EI-500
(Ethernet type)
(TCP/IP UDP/IP)

● Effect of PWM Frequency versus Brightness (Example)

125 kHz Example

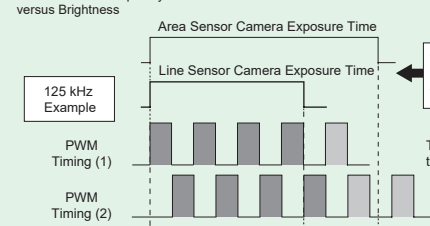

The exposure time of a line sensor camera is generally shorter than that of line sensor cameras.

Timing (1) is 25% brighter than timing (2)

High Frequency 500 kHz Example

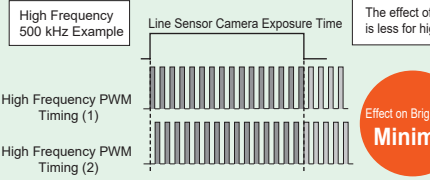

The effect of exposure timing on brightness is less for high frequency types.

Timing (1) is 6% brighter than timing (2)

Effect on Brightness Minimal

PD3 Series



Refer to our website for product details.

CCS PD3

Search



You can also use your smartphone or cell phone.

For quick access.

Common Specifications: EIA-485 Type

Model name	PD3-3024-3-SI(A)	PD3-5024-4-SI(A)	PD3-10024-8-SI(A)
Input voltage	100 to 240 VAC (+10% -15%)		
Lighting method	Regular Emission/Strobe Emission (Without Overdrive)		
Drive method	Constant-voltage system	24 V LIGHT: Constant-voltage system	HLV LIGHT: Constant-current system
Intensity control method	PWM Control Or Light Emission Time Control	24 V LIGHT: PWM control or light emission time control HLV LIGHT: Variable-current control	
No. of channels	3 channels	4 channels	8 channels
Applicable Light Units (rated)	24 VDC Input Lights, 3 Channel Total: 28 W	24 VDC Input Lights, HLV Series (Spot Lighting) 4 Channel Total: 46 W	24 VDC Input Lights, HLV Series (Spot Lighting) 8 Channel Total: 95 W (EL connector: 1 connector 95 W)
PWM frequency	125 kHz		
Error detection display	Front Digital "OCP" Display: Overcurrent Error	Front Digital "OCP" Display: Overcurrent error "EFN" Display: Fan stop error "EID" Display: ID error (HLV series only)	
Overcurrent protection	Activated at output current of 107% min. and can be restored by holding the setting switch for 1 second, or by reinserting power assumes output +/- are not unintentionally short-circuited.		
Power consumption (typ.)	78 VA	70 VA	130 VA
Frequency	50/60 Hz		
Output voltage (rated)	24 VDC		
Dimmer setting	Manual: 256 stages via front setting switch External: Command input via EIA-485 communication		
ON/OFF setting	External: Trigger input or command input via EIA-485 communication		
Emission mode setting	Manual: 11 stages via front setting switch External: Command input via EIA-485 communication		
Error detection output	Command Sending for Overcurrent Detection		
External control connector	Trigger Input: MIL connector 10-pole Dimmer/Emission Mode Setting: e-Con Connector 3-Pole		
Operating environment	Temperature: 0 to 40°C, Humidity: 20 to 85% (with no condensation)		
Storage environment	Temperature: -20 to 60°C, Humidity: 20 to 85% (with no condensation)		
Cooling method	Natural air-cooling	Forced cooling	
CE marking	Safety standard: Conforms to EN61010-1 EMC standard: Conforms to EN61326-1 Class A		
Electrical appliance and Material safety law	Specified electrical equipment (DC power supply) compliant with technical standards		
Material/Surface processing	Material: Aluminum, resin, Surface processing: Navy anodizing		
Weight	600 g max.	1,200 g max.	1,500 g max.
Accessories	2 m 3-prong AC power cable with ground terminal, Instruction Manual x 1, Bottom installation bracket x 1 set (PD3-5024-4-SI(A)/10024-8-SI(A))		

EIA-485 Communication Cable Connection Method

EIA-485 communication types identify based on ID switch settings, enables up to 4 units to be connected on one signal line. The options differ depending on the number of units to be connected. Refer to the following connection diagram.

For 1 connected unit

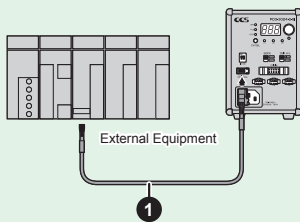

For 4 connected units

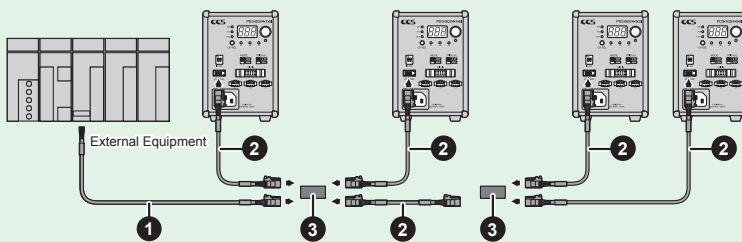

* illustration shows PD3-3024-3-SI

Options

1 EXCB2-E3-3

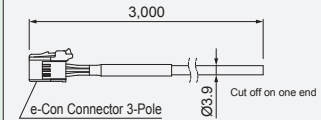

2 EXCB2-E3-E3-0.2

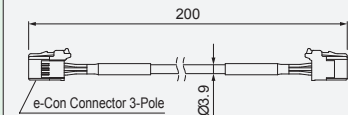

3 ECNR-E3CN4



PD3
PD2
PSB
POD
PTU2
PF
CN-EPOE
CN-4024-2-EIPT
PB-2430-1
CC-ST-1024
PJ2
PJ
CC-PJ-0707
PSCC
PSB4
PSB3-30024
Band-Pass Filters
Lens Filters
Diffusion Plates
Polarizing Plates
Light Control Films
Fixtures, etc.
Brackets
SM/EL Cables

Dimensions (mm)

PD3-3024-3-PI / PD3-3024-3-EI(A) / PD3-3024-3-SI(A) / PD3-3024-3-PT / PD3-3024-3-ET(A) / PD3-5024-3-PT / PD3-5024-3-ET(A)

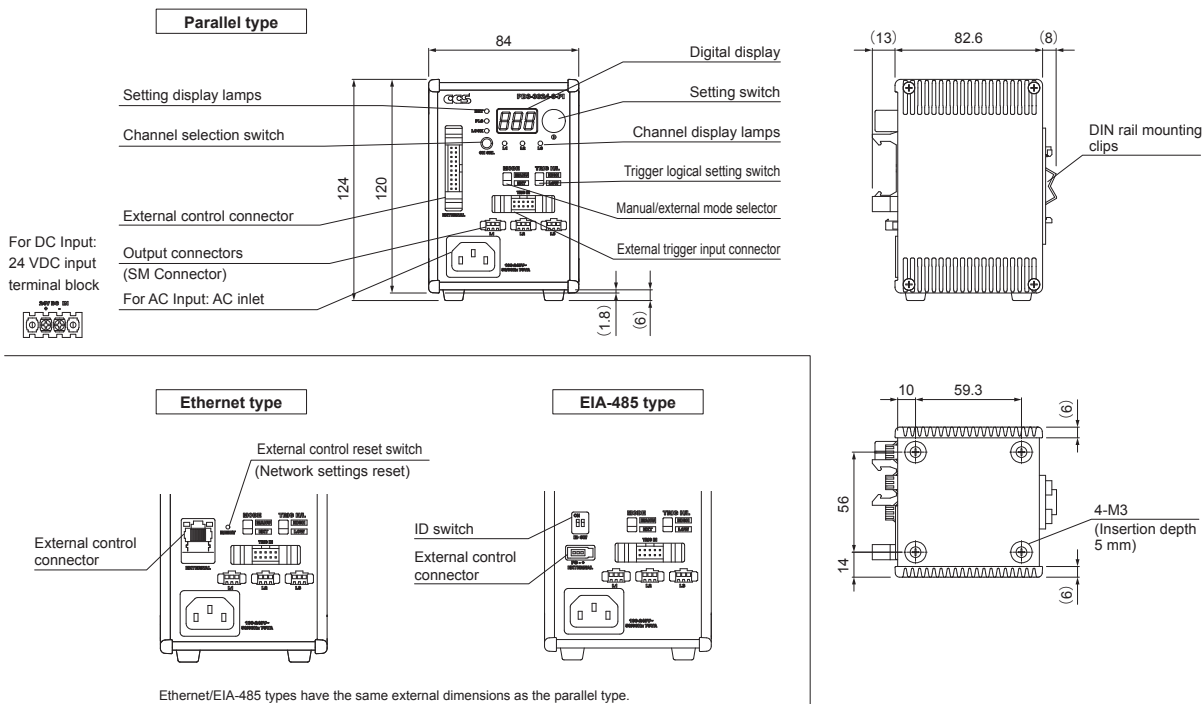

Dimensions (mm)

PD3-5024-4-PI(A) / PD3-5024-4-EI(A) / PD3-5024-4-SI(A) / PD3-5024-4-PT(A) / PD3-5024-4-ET(A)

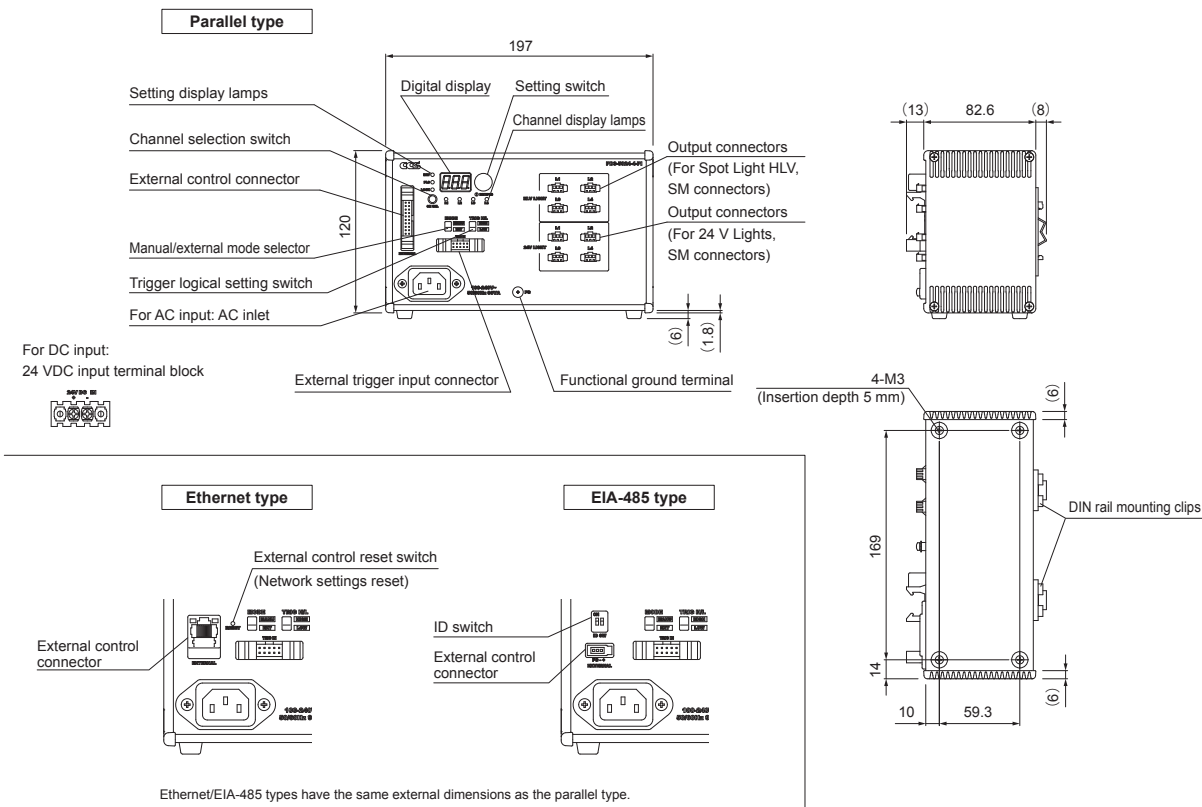

PD3 Series



Refer to our website for product details.

CCS PD3

Search



You can also use your smartphone or cell phone.

For quick access.

Dimensions (mm)

PD3-10024-8-PI / PD3-10024-8-EI(A) / PD3-10024-8-SI(A)

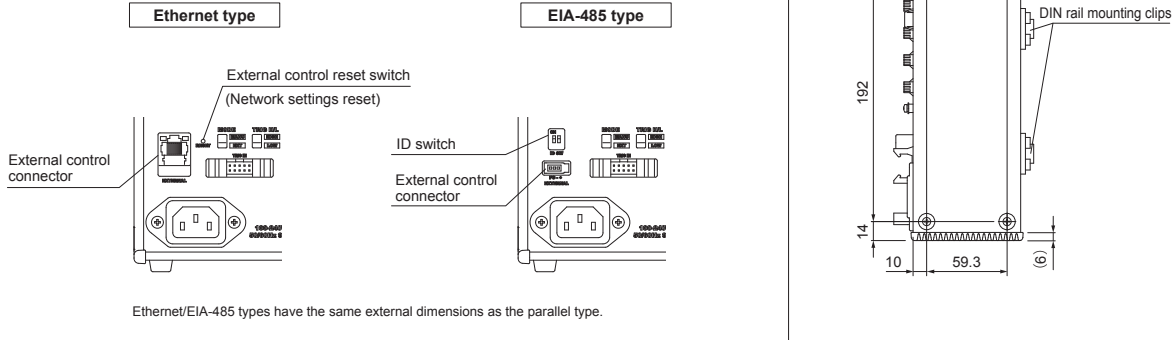
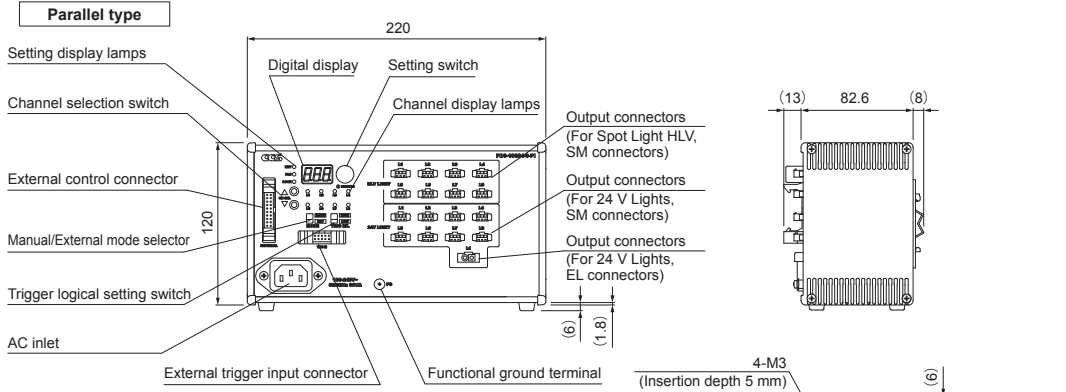

Differences Between Specifications and Models

[(A) attached to end of model number] Ex.: PD3-3024-3-EI → PD3-3024-3-EI(A)

	Contents Changed	Applicable Models
Software Change	<ul style="list-style-type: none"> Command specifications for changing the setting values for dimmer control commands (F commands) as a batch have been added. Command specifications for changing the status of each channel for ON/OFF commands (L commands) as a batch have been added. 	PD3-3024-3-EI(A) / PD3-3024-3-SI(A) / PD3-3024-3-ET(A) / PD3-5024-4-EI(A) / PD3-5024-4-SI(A) / PD3-5024-4-ET(A) / PD3-5024-3-ET(A) / PD3-10024-8-EI(A) / PD3-10024-8-SI(A)
DIN Rail Mount Added	<ul style="list-style-type: none"> The number of DIN rail mounts for 50 W power supplies has increased from 1 to 2. 	PD3-5024-4-PI(A) / PD3-5024-4-EI(A) / PD3-5024-4-SI(A) / PD3-5024-4-PT(A) / PD3-5024-4-ET(A)

Options

Trigger Voltage Level Conversion Unit

- Can be used when performing trigger input from a device with 3.3 V, 5 V or 12 V output (PCB, etc.).
- It can also be used when performing trigger input using a contact signal such as a relay.

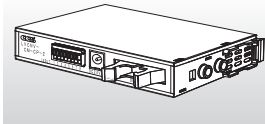

Be sure to prepare an AC adapter with 24 V output separately as a control unit source.

Connection Example

When driving with non-voltage contact

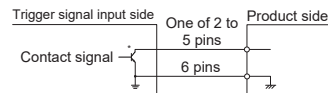

* Elements used: Photocoupler, open collector or driver IC

Trigger signal input	Trigger signal output	Photocoupler inside the control unit for LED lights
Open	ON	ON
Short	OFF	OFF

When driving with high voltage signal

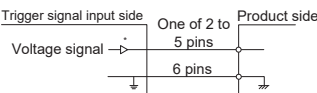

* Elements used: Buffer, HS-CMOS or driver IC

Trigger signal input	Trigger signal output	Photocoupler inside the control unit for LED lights
High	ON	ON
Low	OFF	OFF

Trigger signal output	Trigger signal input	Description
ON	High	Input voltage range: +3 to 13.2 VDC, input current: Approximately 8 mA (at 12 VDC input, per terminal)
	Open	Terminal voltage: Approx. 2.9 V
OFF	Low/Short	Input voltage range: 0.0 to +0.5 VDC, input current: Approximately -3 mA (at 0 VDC input, per terminal)

When the trigger signal to this product is set to High or Open (non-conducting), the trigger signal output from this product turns ON. When it is set to Low or Short (conducting), the trigger signal output is turned OFF.

Model Name: LVCNV-CM-CP-2-MG-WOC

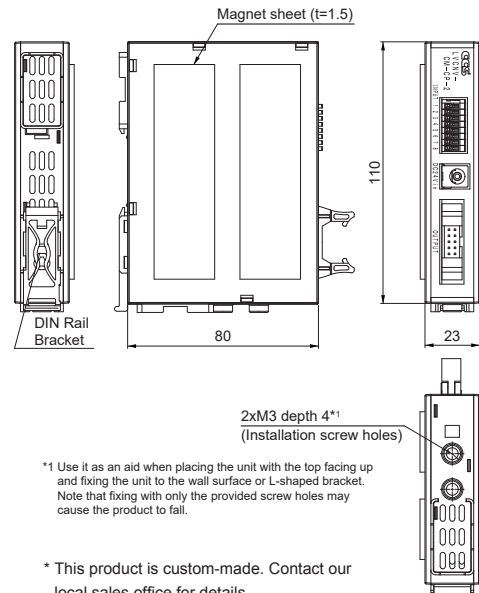

*1 Use it as an aid when placing the unit with the top facing up and fixing the unit to the wall surface or L-shaped bracket. Note that fixing with only the provided screw holes may cause the product to fall.

* This product is custom-made. Contact our local sales office for details.

PD3
PD2
PSB
POD
PTU2
PF
CN-EPOE
CN-4024-2-EIPT
PB-2430-1
CC-ST-1024
PJ2
PJ
CC-PJ-0707
PSCC
PSB4
PSB3-30024
Band-Pass Filters
Lens Filters
Diffusion Plates
Polarizing Plates
Light Control Films
Fixtures, etc.
Brackets
SM/EL Cables

Options

External control cables

Parallel communication cable

Used for performing external control via parallel communication. You can select the channel, intensity setting and lighting mode (continuous, ON/OFF and strobe modes). The Trigger Input Cable shown (EXCB2-M10-3) below is needed for ON/OFF lighting and strobe lighting.

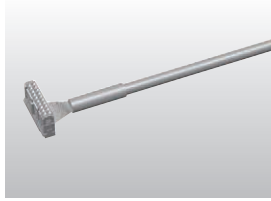

Model name: EXCB2-M20-3

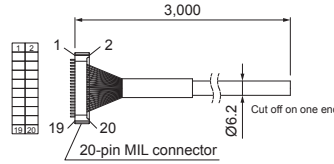

PIN No.	Line color	Marking	PIN No.	Line color	Marking
1	Orange	Black1	11	Orange	Black2
2	Orange	Red1	12	Orange	Red2
3	Gray	Black1	13	Gray	Black2
4	Gray	Red1	14	Gray	Red2
5	White	Black1	15	White	Black2
6	White	Red1	16	White	Red2
7	Yellow	Black1	17	Yellow	Black2
8	Yellow	Red1	18	Yellow	Red2
9	Pink	Black1	19	Pink	Black2
10	Pink	Red1	20	Pink	Red2

Dimensions (mm)

Trigger input cable

Cable through which external trigger signals are input by parallel bit method. Used when performing ON/OFF or strobe lighting using an external trigger signal.

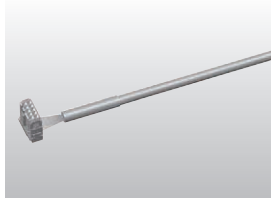

Model name: EXCB2-M10-3

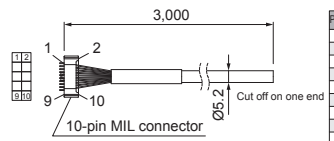

PIN No.	Line color	Marking
1	Orange	Black1
2	Orange	Red1
3	Gray	Black1
4	Gray	Red1
5	White	Black1
6	White	Red1
7	Yellow	Black1
8	Yellow	Red1
9	Pink	Black1
10	Pink	Red1

EIA-485 communication cable

Used for performing external control via EIA-485 communication. You can select the channel, intensity setting, ON/OFF setting and lighting mode (continuous, ON/OFF and strobe modes).

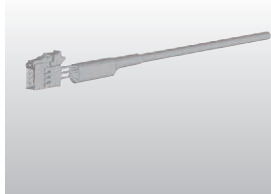

Model name: EXCB2-E3-3

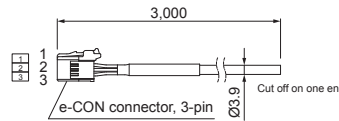

PIN No.	Line color	Embedded line color
1	Black	None
2	Black	White
3 (shielded)	Drain wire	None

EIA-485 communication relay cable

Relay cable necessary if using with two or more PD3 series units connected for EIA-485 communication.

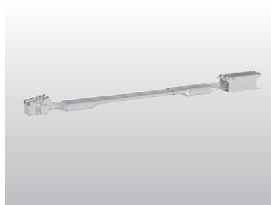

Model name: EXCB2-E3-E3-0.2

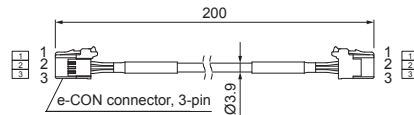

Refer to the material "Connecting EIA-485 Communications Cables" on the CCS website for information on multi-drop wiring connections. You can download this information from the product website page.

EIA-485 communication relay connector

Model name: ECNR-E3CN4



Parallel communication/Trigger input branch cable

Branch cable that combines parallel communication and trigger input cables into a single cable.

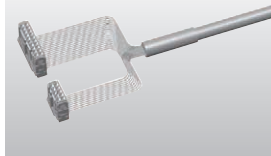

Model name: EXCB2-M10M20-3

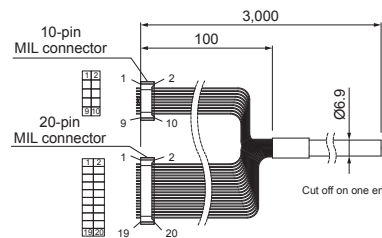

20-pin MIL connector		
PIN No.	Line color	Marking
1	Orange	Black2
2	Orange	Red2
3	Gray	Black2
4	Gray	Red2
5	White	Black2
6	White	Red2
7	Yellow	Black2
8	Yellow	Red2
9	Pink	Black2
10	Pink	Red2

10-pin MIL connector		
PIN No.	Line color	Marking
1	Orange	Black1
2	Orange	Red1
3	Gray	Black1
4	Gray	Red1
5	White	Black1
6	White	Red1
7	Yellow	Black1
8	Yellow	Red1
9	Pink	Black1
10	Pink	Red1

Base brackets

Bracket for securing PD3 series units to the floor, shelving and similar locations.

Base Brackets are included with PD3-5024-4 and PD3-10024-8 models.



Model name: BK-PD3

