

1 2 3 4 5 6

A

B

C

D

A

B

C

D

REVISIONS				
ZONE	REV.	DESCRIPTION	DATE	APPROVED
	A	RELEASED FOR PRODUCTION	1/26/2022	DMM
A3	B	UPDATED WITH 37mm O.C. ARM	3/14/2022	DMM

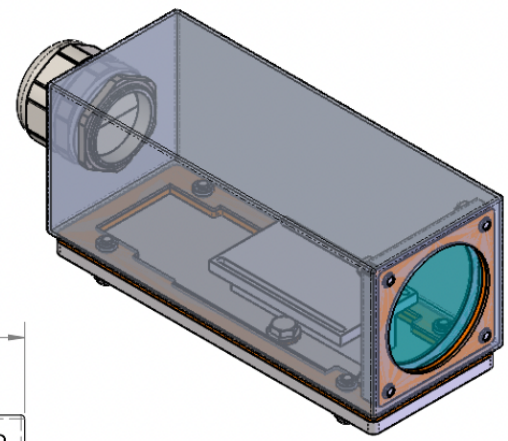
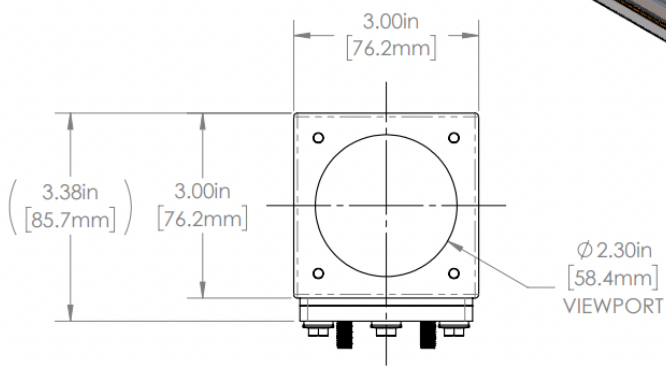
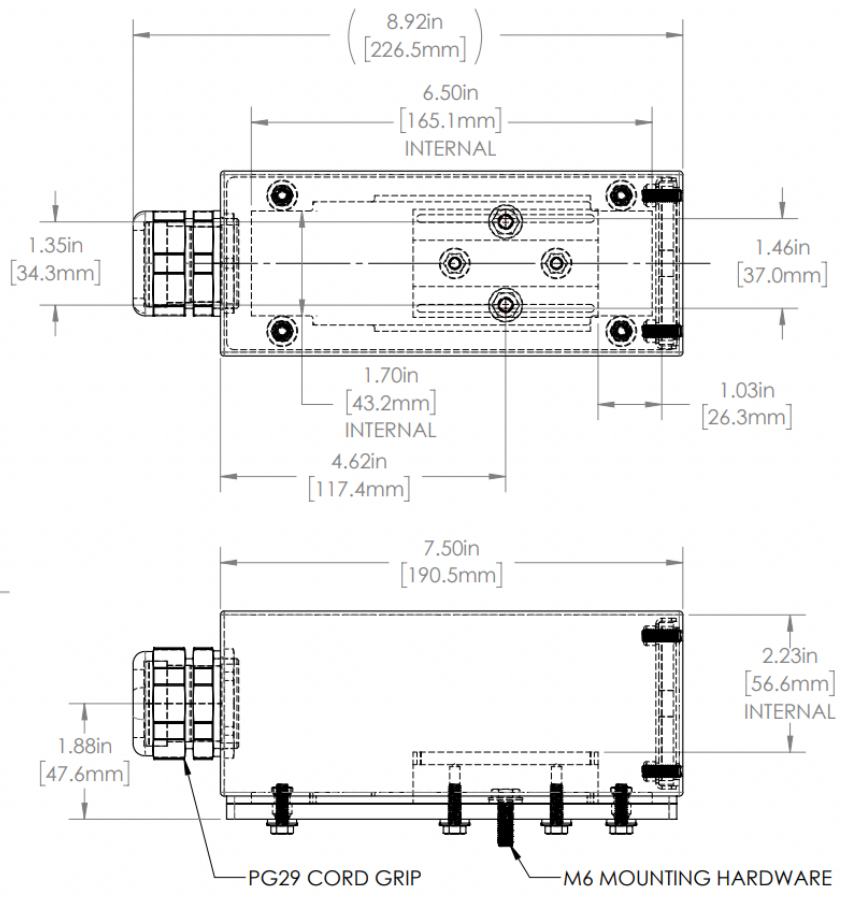

30S SERIES PROPERTIES TABLE		
ENVIRONMENT RATING	IP68*	
	(*RATING MAY CHANGE IF INSTALLER MILLS CABLE GLAND OUTSIDE OF TOLERANCE)	
COMPONENT	MATERIAL	FINISH
BODY/BASE	316 SS	BURNISHED
VIEWPORT	CLEAR ACRYLIC	ABR2
GASKET	SILICONE	NONE
ARM/ADAPTOR	6061 ALUMINUM	NONE
HARDWARE	316 SS - EXTERNAL, 18-8 SS - INTERNAL	NONE



MACHINING		SHEET METAL		
X.X	0.0250"	HOLE TO HOLE (SAME SURFACE)	X.X	0.030"
X.XX	0.0100"		X.XX	0.010"
X.XXX	0.0050"		X.XXX	0.005"
X.XXXX	0.0005"		X.XXXX	0.0005"
ANGULAR	0.5°	HOLE TO FOLDED EDGE	X.X	0.035°
DEBURR	ALL		X.XX	0.025°
		FOLD TO FOLD	X.XX	0.045°
			X.XX	0.035°
			X.XXX	0.020°
			ANGULAR	1.0°

APG Vision LLC 4055 Alpha Drive Allison Park, PA 15101 USA Phone +1 (412) 487-8211 apgvision.com		<b>apgvision</b>	
DESCRIPTION: 30S 7.5IN BODY WITH EXTENDED OPENING, ACRYLIC VIEWPORT, 37mm SLOTS O.C. ARM, & PG29 CORD GRIP			
MATERIAL: SEE BOM			
FINISH: SEE BOM			
DRAWN BY: GAS	DATE: 1/26/2022	SCALE: 1:2	SHT-SIZE: APPROX. WEIGHT (LBS) B 3.6638
CHECKED BY: DMM	DATE: 1/26/2022	PART NUMBER: 30S-FJ	REVISION: B
Sheet 1 of 1			

THIS PRINT IS THE PROPERTY OF APG VISION LLC. THE INFORMATION CONTAINED HEREIN IS CONFIDENTIAL. IT IS NOT TRANSFERABLE. IT IS FURNISHED WITH THE CLEAR UNDERSTANDING THAT IT IS NOT TO BE REPRODUCED, REPRODUCED OR USED IN ANY PROCESSES OF MANUFACTURING WITHOUT WRITTEN PERMISSION FROM THE OWNER AND IS RETURNABLE UPON DEMAND. ANY VIOLATION OF THE PATENT RIGHTS SHOWN HEREIN, WHETHER IN PART OR WHOLE, WILL BE PROSECUTED.

AS PART OF OUR POLICY OF CONTINUING DEVELOPMENT, APG VISION LLC RESERVES THE RIGHT TO ALTER SPECIFICATIONS WITHOUT PRIOR NOTICE.

1 2 3 4 5 6