

| REVISIONS | | | | |
|-----------|------|------------------------------------|-----------|----------|
| ZONE | REV. | DESCRIPTION | DATE | APPROVED |
| | A | REDRAWN RELEASED FOR PRODUCTION | 8/26/2021 | DMM |

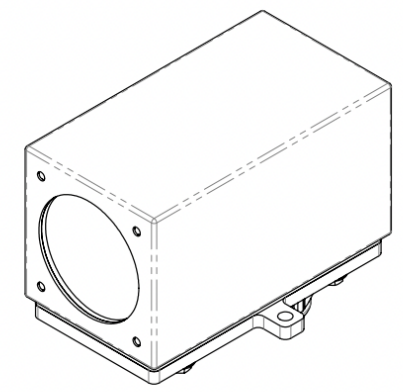

| 30S SERIES PROPERTIES TABLE | | |
|-----------------------------|--|---------------|
| ENVIRONMENT RATING | IP68* | |
| | (*RATING MAY CHANGE IF INSTALLER MILLS CABLE GLAND OUTSIDE OF TOLERANCE) | |
| COMPONENT | MATERIAL | FINISH |
| BODY/BASE | 316 SS | BURNISHED |
| VIEWPORT | CLEAR ACRYLIC | ABR2 |
| GASKET | SILICONE | NONE |
| ARM/ADAPTOR | 5052 ALUM | NONE |
| HARDWARE | 316 SS - EXTERNAL, 18-8 SS - INTERNAL | NONE |



| TOLERANCES UNLESS OTHERWISE SPECIFIED | |
|---------------------------------------|--|
| MACHINING | SHEET METAL |
| X.X 0.0250" | HOLE TO HOLE (SAME SURFACE) X.X 0.030" |
| X.XX 0.0100" | X.XX 0.010" |
| X.XXX 0.0050" | X.XXX 0.010" |
| X.XXXX 0.0005" | X.XXXX 0.005" |
| ANGULAR 0.5° | HOLE TO FOLDED EDGE X.X 0.035" |
| DEBURR ALL | X.XX 0.025" |
| | X.XXX 0.015" |
| | FOLD TO FOLD X.X 0.045" |
| | X.XX 0.035" |
| | X.XXXX 0.020" |
| | ANGULAR 1.0° |

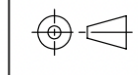

THIS PRINT IS THE PROPERTY OF APG VISION LLC. THE INFORMATION CONTAINED HEREIN IS CONFIDENTIAL. IT IS NOT TRANSFERABLE. IT IS FURNISHED WITH THE CLEAR UNDERSTANDING THAT IT IS NOT TO BE REPRODUCED, COPIED, OR USED IN ANY PROCESS OF MANUFACTURING WITHOUT WRITTEN PERMISSION FROM THE OWNER AND IS RETURNABLE UPON DEMAND. ANY INFRINGEMENT UPON THE PATENT RIGHTS SHOWN HEREIN, WHETHER IN PART OR WHOLE, WILL BE PROSECUTED.

AS PART OF OUR POLICY OF CONTINUING DEVELOPMENT, APG VISION LLC RESERVES THE RIGHT TO ALTER SPECIFICATIONS WITHOUT PRIOR NOTICE.

| | | | | |
|--|--------------------|------------------------|----------------|---------------------------------|
| APG Vision LLC 4055 Alpha Drive Allison Park, PA 15101 USA Phone +1 (412) 487-8211 apgvision.com | | | | |
| apgvision | | | | |
| DESCRIPTION: 30S 5.5IN SEALED BODY WITH PG21 CORD GRIP | | | | |
| MATERIAL: SEE PROPERTIES TABLE | | | | |
| FINISH: SEE PROPERTIES TABLE | | | | |
| DRAWN BY: TWD | DATE: 8/26/2021 | SCALE: 1:2 | SHT-SIZE: B | APPROX. WEIGHT (LBS): 2.6721 |
| CHECKED BY: DMM | DATE: 8/26/2021 | PART NUMBER: 30S-IF | REVISION: A | |
| Sheet 1 of 1 | | | | |