

REVISIONS				
ZONE	REV.	DESCRIPTION	DATE	APPROVED
	A	RELEASED FOR PRODUCTION	11/23/2021	DMM

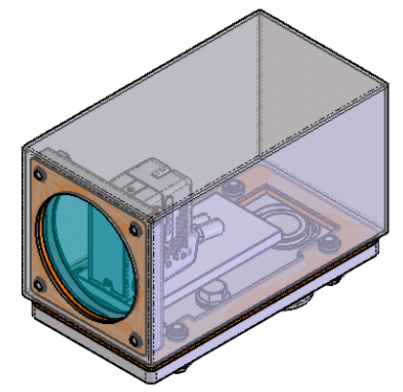

**30S SERIES PROPERTIES TABLE**

<b>ENVIRONMENT RATING</b>	IP68*	
	(*RATING MAY CHANGE IF INSTALLER MILLS CABLE GLAND OUTSIDE OF TOLERANCE)	
<b>COMPONENT</b>	<b>MATERIAL</b>	<b>FINISH</b>
BODY/BASE	316 SS	BURNISHED
VIEWPORT	CLEAR FLOWCOAT ACRYLIC	ABR2
GASKET	SILICONE	NONE
ARM/ADAPTOR	6061 ALUM	NONE
HARDWARE	316 SS - EXTERNAL, 18-8 SS - INTERNAL	NONE

MACHINING		SHEET METAL	
XX	0.0250"	HOLE TO HOLE (SAME SURFACE)	XX
XXX	0.0100"	XX	0.0300"
X.XXX	0.0050"	XXX	0.0100"
X.XXXX	0.0005"	X.XXX	0.0050"
ANGULAR	0.0005"	X.XXXX	0.0005"
DEBURR ALL	0.5"	HOLE TO FOLDED EDGE	XX
		XX	0.035"
		X.XXX	0.0025"
		X.XXX	0.015"
		FOLD TO FOLD	XX
		XX	0.045"
		X.XXX	0.035"
		X.XXX	0.020"
		ANGULAR	1.0"

THIS PRINT IS THE PROPERTY OF APG VISION LLC. THE INFORMATION CONTAINED HEREIN IS CONFIDENTIAL. IT IS NOT TRANSFERABLE. IT IS FURNISHED WITH THE CLEAR UNDERSTANDING THAT IT IS NOT TO BE TRACED, REPRODUCED OR USED IN ANY PROCESS OF MANUFACTURING WITHOUT WRITTEN PERMISSION FROM THE OWNER AND IS NOT RETURNABLE UPON DEMAND. ANY INFRINGEMENT OF THE PATENT RIGHTS SHOWN HEREIN, WHETHER IN PART OR WHOLE, WILL BE PROSECUTED.

AS PART OF OUR POLICY OF CONTINUING DEVELOPMENT, APG VISION LLC RESERVES THE RIGHT TO ALTER SPECIFICATIONS WITHOUT PRIOR NOTICE.

APG Vision LLC 4055 Alpha Drive Allison Park, PA 15101 USA Phone +1 (412) 487-8211 apgvision.com				
DESCRIPTION: <b>30S 5.5IN SEALED BODY WITH PG16 CORD GRIP FOR BANNER ABR3000</b>				
MATERIAL: SEE PROPERTIES TABLE				
FINISH: SEE PROPERTIES TABLE				
DRAWN BY: GAS	DATE: 11/23/2021	SCALE: 1:2	SHT-SIZE: B	APPROX. WEIGHT (LBS): 2.7471
CHECKED BY: DMM	DATE: 11/23/2021	PART NUMBER: <b>30S-IZ</b>		REVISION: A
Sheet 1 of 1				