

1 2 3 4 5 6

A

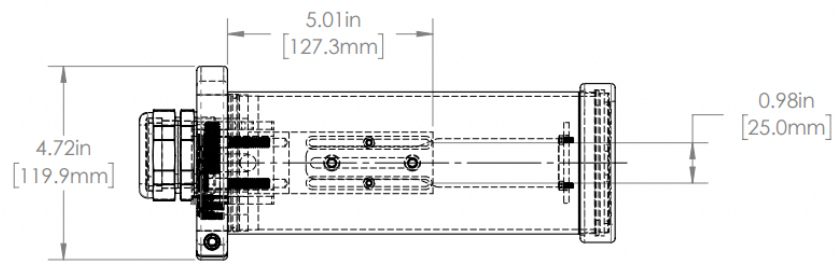

B

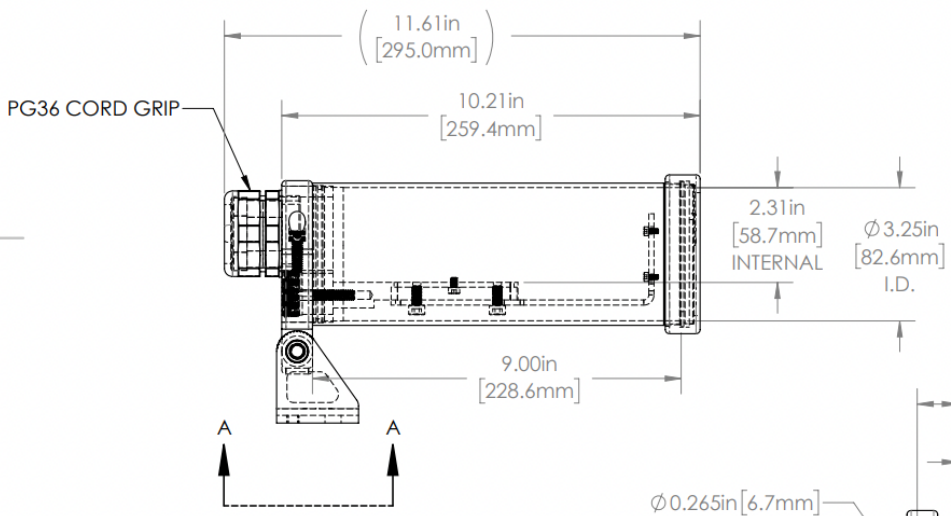

C

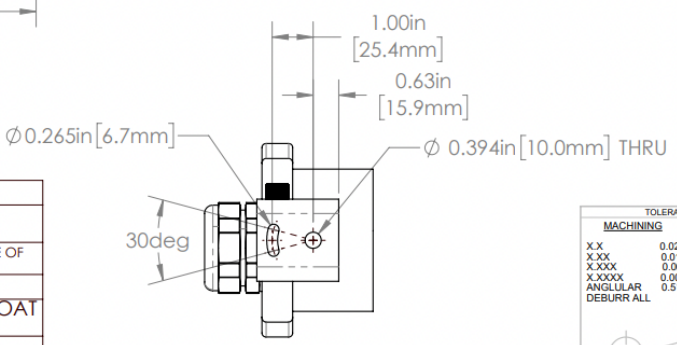

REVISIONS				
ZONE	REV.	DESCRIPTION	DATE	APPROVED
	A	RELEASED FOR PRODUCTION	10/11/2021	DMM

A

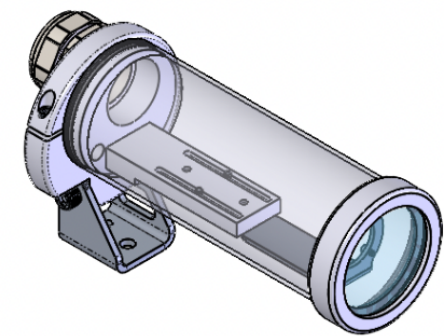

B

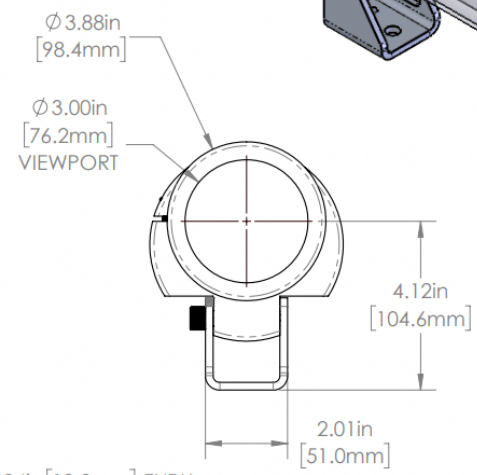

C



35C SERIES PROPERTIES TABLE

ENVIRONMENT RATING	IP68*	
	(*RATING MAY CHANGE IF INSTALLER MILLS CABLE GLAND OUTSIDE OF TOLERANCE)	
COMPONENT	MATERIAL	FINISH
BODY/BASE/BARREL	6061 ALUMINUM	CLEAR HARDCOAT ANODIZED
FOOT	304 SS	BURNISHED
VIEWPORT	SODA LIME GLASS	NONE
GASKET	VITON	NONE
ARM	6061 ALUMINUM	NONE
BRACKET	5052 ALUMINUM	NONE
HARDWARE	18-8 SS	NONE

D

MACHINING		SHEET METAL	
X.X	0.0250"	HOLE TO HOLE (SAME SURFACE)	X.X
X.XX	0.0100"	X.XX	0.030"
X.XXX	0.0050"	X.XX	0.010"
X.XXXX	0.0005"	X.XXX	0.005"
ANGULAR	0.5°	HOLE TO FOLDED EDGE	X.X
DEBURR ALL		X.X	0.035"
		X.XX	0.025"
		X.XXX	0.015"
		FOLD TO FOLD	X.X
		X.X	0.045"
		X.XX	0.035"
		X.XXX	0.020"
		ANGULAR	1.0°

APG Vision LLC
4055 Alpha Drive
Allison Park, PA 15101 USA
Phone +1 (412) 487-8211
apgvision.com



DESCRIPTION:
35C 9IN BARREL WITH 4.51IN ARM SLOTTED 25mm O.C. & RING LIGHT BRACKET

MATERIAL: **SEE BOM**

FINISH: **SEE BOM**

THIS PRINT IS THE PROPERTY OF APG VISION LLC. THE INFORMATION CONTAINED HEREIN IS CONFIDENTIAL. IT IS NOT TRANSFERABLE. IT IS FURNISHED WITH THE CLEAR UNDERSTANDING THAT IT IS NOT TO BE TRACED, REPRODUCED OR USED IN ANY PROCESS OF MANUFACTURE WITHOUT WRITTEN PERMISSION FROM THE OWNER AND IS RETURNABLE UPON DEMAND. ANY INFRACTION OF THE PATENT RIGHTS IS PROHIBITED, WHETHER IN PART OR WHOLE, WILL BE PROSECUTED.

AS PART OF OUR POLICY OF CONTINUING DEVELOPMENT, APG VISION LLC RESERVES THE RIGHT TO ALTER SPECIFICATIONS WITHOUT PRIOR NOTICE.

DRAWN BY: DMM	DATE: 10/11/2021	SCALE: 1:3	SHT-SIZE: B	APPROX. WEIGHT (LBS): 3.8152
CHECKED BY: DMM	DATE: 10/11/2021	PART NUMBER: 35C-LT	REVISION: A	

D

1 2 3 4 5 6