

LINEA™ 2 4k Color 5GigE

L2-GC-04k04T-00 Line Scan Camera



KEY FEATURES

- 4096 x3 pixel resolution
- 7 x7 µm pixel size
- High speeds over 5GigE
- RGB native colors
- Multiple regions of interest for calibration and data reduction
- 4 programmable coefficient sets
- Programmable I/Os
- Compact form factor
- Precision Time Protocol
- 5GigE, PoE

TYPICAL APPLICATIONS

- Automated optical inspection
- Optical sorting systems
- Materials grading and inspection
- Web inspection
- Printing inspection
- General purpose machine vision

5x the Bandwidth of Linea with 5GigE

Take your system to the next level with dazzling performance over 5GigE speeds. Trilinear RGB, this is Linea like you've never seen it before.



SPECIFICATIONS

	L2-GC-04k04T-00
Resolution	4096 x3 pixels
Line Rate	40 kHz x3 RGB
Pixel Size	7 x7 µm
Interface	5GigE
Data Format	8 or 12 bit
Dynamic Range	71 dB
Full Well	32 ke-
Read Noise	9.5 e-
Power	+12 to +24V DC HD15 Connector or 48V POE
Power Dissipation	13 W
Operating Temp	-10 to 65°C
Camera Size	62 x 62 x 49.3 mm
Camera Weight	< 280 g
Optical Interface	M42
Control & Data	GigE

SPECIFICATIONS

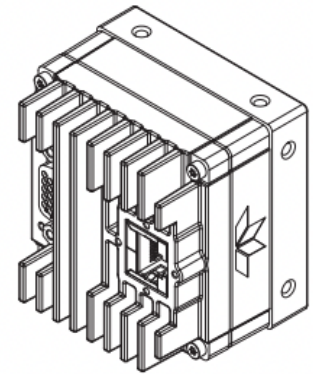
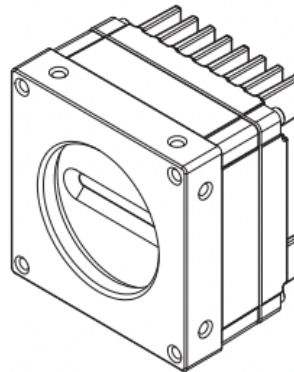
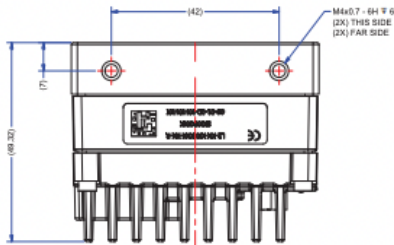
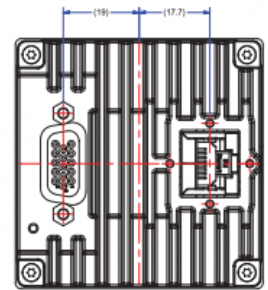
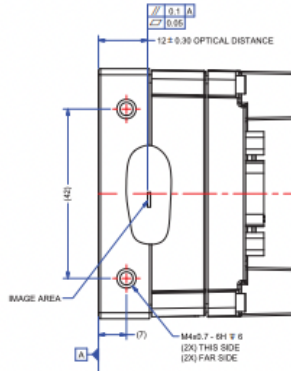
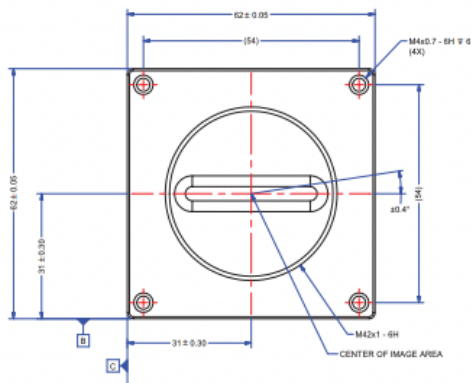
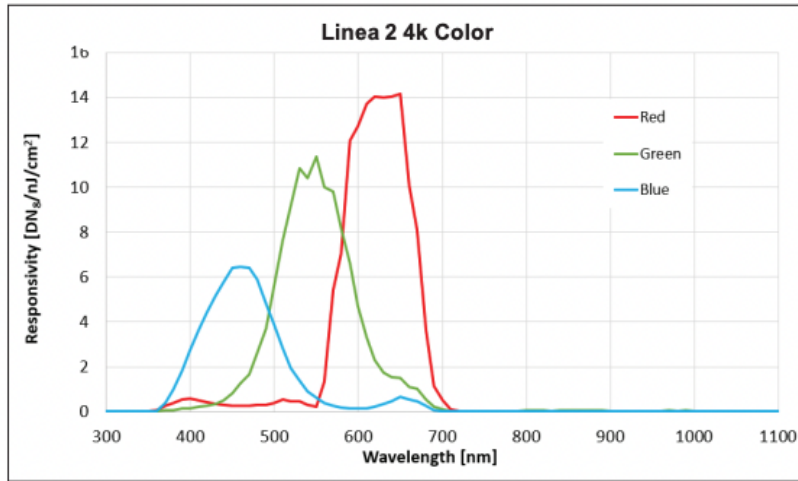

NOTES:
1. UNITS: MILLIMETERS.
2. IMAGE AREA IS ALIGNED TO DATUMS \square \square \square \square

FOR MORE INFORMATION CONTACT:

AMERICAS Boston, USA | +1 978-670-2000 | TDI_sales.americas@teledynedalsa.com
 EUROPE Krailling, Germany | +49 89-89-54-57-3-80 | TDI_sales.europe@teledynedalsa.com
 ASIA PACIFIC Tokyo, Japan | +81 3-5960-6353 | TDI_sales.asia@teledynedalsa.com
 Shanghai, China | +86 21-3368-0027 | TDI_sales.asia@teledynedalsa.com

This document does not contain information whose export/transfer/disclosure is restricted by the Canadian Export Control regulation. Teledyne DALSA has its corporate offices in Waterloo, Canada. Teledyne DALSA reserves the right to make changes at any time without notice. © Teledyne DALSA.

Number: 03-070-25009-00
Revision Date: 2023 04 14