

GENIE™ NANO-10GigE CAMERAS

KEY FEATURES

- 10 GigE Ethernet port & hardware
- Industry's smallest 67M 10GigE Vision camera
- Simplified set-up with field proven Sopera LT software featuring CamExpert
- Engineered to accommodate industrial environment with a ruggedized screw mount RJ-45 connector

PROGRAMMABILITY

- Higher frame rates achievable in partial scan mode
- Global electronic shutter with exposure control
- Multi-exposure feature
- Multi-ROI feature up to 16 x Regions of Interest
- Metadata support
- IEEE1588 (Precision Time Protocol) support
- Binning
- Look-up-table and More

RELIABILITY

- Robust all-metal body
- 3 year warranty
- Trigger to Image Reliability (T2IR) framework improves the reliability of your inspection system and protects you from data loss

TYPICAL APPLICATIONS

- Electronics manufacturing inspection
- Intelligent traffic systems
- Aerial Imaging
- Sport and Entertainment

REGULATORY COMPLIANCE

- GenICam, GigE Vision 2.0, CE, FCC, and RoHS compliant

Compact GigE Vision cameras with unprecedented speed and uncompromised image quality.

The new Genie™ Nano-10GigE series delivers a futureproof and scalable solution with significantly higher interface speeds and resolutions, offering system designers an easy integration path for application upgrades requiring higher speed data capture and transfers. Coupling a compact 59 mm x 59 mm form factor, system designers can transition from 1, 2.5, 5GigE to 10GigE Vision without the need for software changes.

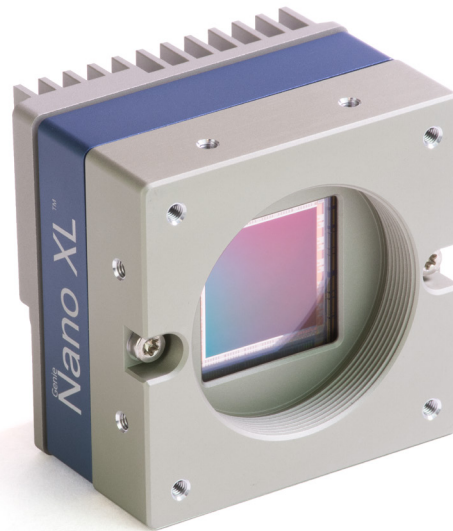

GENIE NANO-10GigE INDIVIDUAL MODEL SPECIFICATIONS

	Active Resolution	Sensor Model	Frame Rate	Pixel Size	Dynamic Range	Max. Image Circle	Data Format	Model Part Numbers
Nano-10GigE-M6200	6,144 x 6,144	Teledyne e2v Emerald 36M	18.5 fps	2.5 µm	62 dB	1.4"	8 or 10-bit Mono	G6-GM31-M6205
Nano-10GigE-C6200	6,144 x 6,144	Teledyne e2v Emerald 36M	18.5 fps	2.5 µm	62 dB	1.4"	8 or 10-bit Bayer	G6-GC31-C6205
Nano-10GigE-M8200	8,192 x 8,192	Teledyne e2v Emerald 67M	13.8 fps	2.5 µm	62 dB	APS-C	8 or 10-bit Mono	G6-GM31-M8205
Nano-10GigE-C8200	8,192 x 8,192	Teledyne e2v Emerald 67M	13.8 fps	2.5 µm	62 dB	APS-C	8 or 10-bit Bayer	G6-GC31-C8205

GENIE NANO-10GigE FAMILY SPECIFICATIONS (COMMON TO ALL MODELS)

Feature	GENIE NANO-10GigE (XL Casing) Applicable to p/n : G6-Gxxx-xxxx5
Data Output Transfer	Gigabit Ethernet (10Gbps, 5Gbps, 2.5Gbps, and 1Gbps auto-negotiated)
Exposure Control	Automatic, programmable, or via external trigger
I/O Ports	2 opto-isolated inputs, 3 opto-isolated outputs
Lens Mount	M42-mount
Size (L x H x W)	41 mm x 59 mm x 59 mm
Mass	183 g
Operating Temp	-20 to +60°C (Housing Temperature)
Power Supply	10 to 36V or Power Over Ethernet (POE)
Power Dissipation (model dependent)	12.5 W
Data Connector	Standard or screw mount RJ-45
Power and I/O Connector	SAMTEC TFM-105 type
Camera Specification	GigE Vision v2.0
Software Platform	Teledyne Sopera LT 8.6 or newer for Windows, Teledyne DALSA GigE-V for Linux or 3rd Party GenICam compliant SDK

RESPONSIVITY GRAPHS

Spectral Sensitivity Characteristics

Excludes lens characteristics and light source characteristics

GENIE NANO-10GigE M8200 / M6200

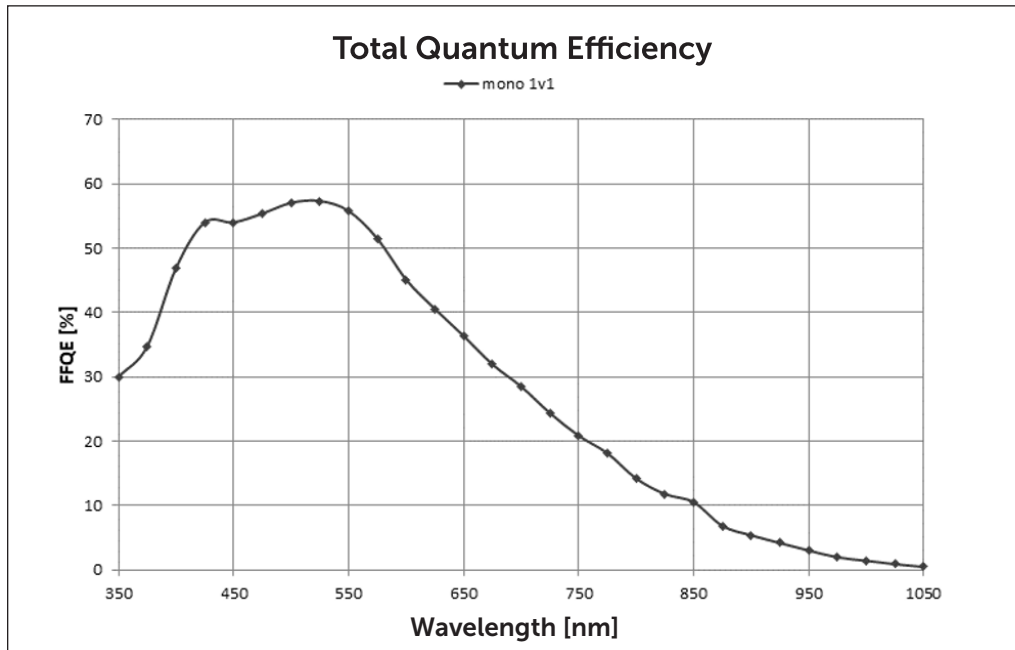

GENIE NANO-10GigE C8200 / C6200

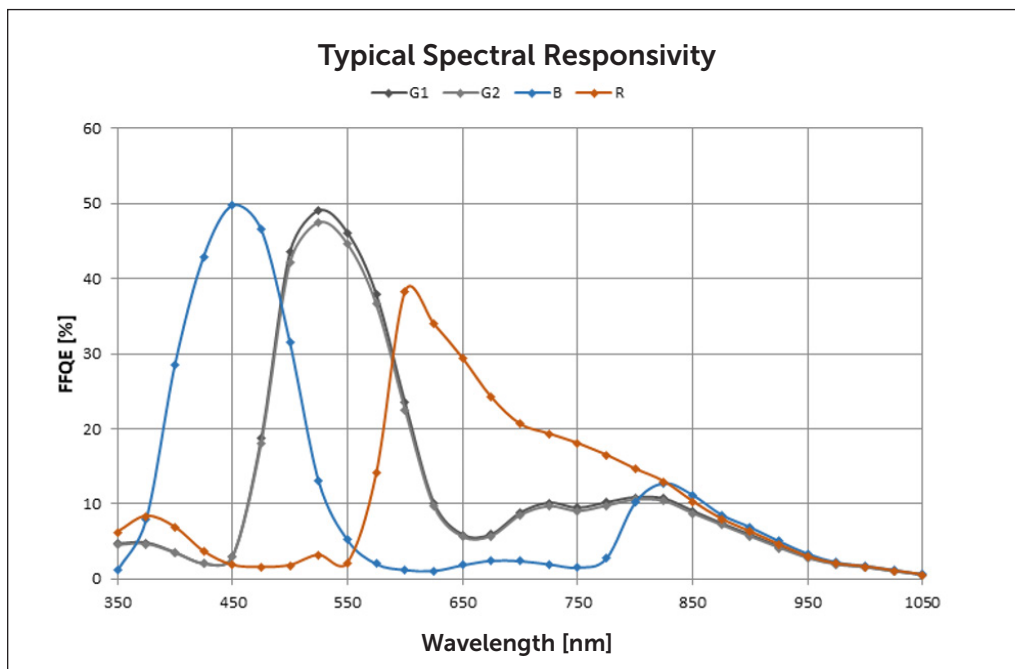

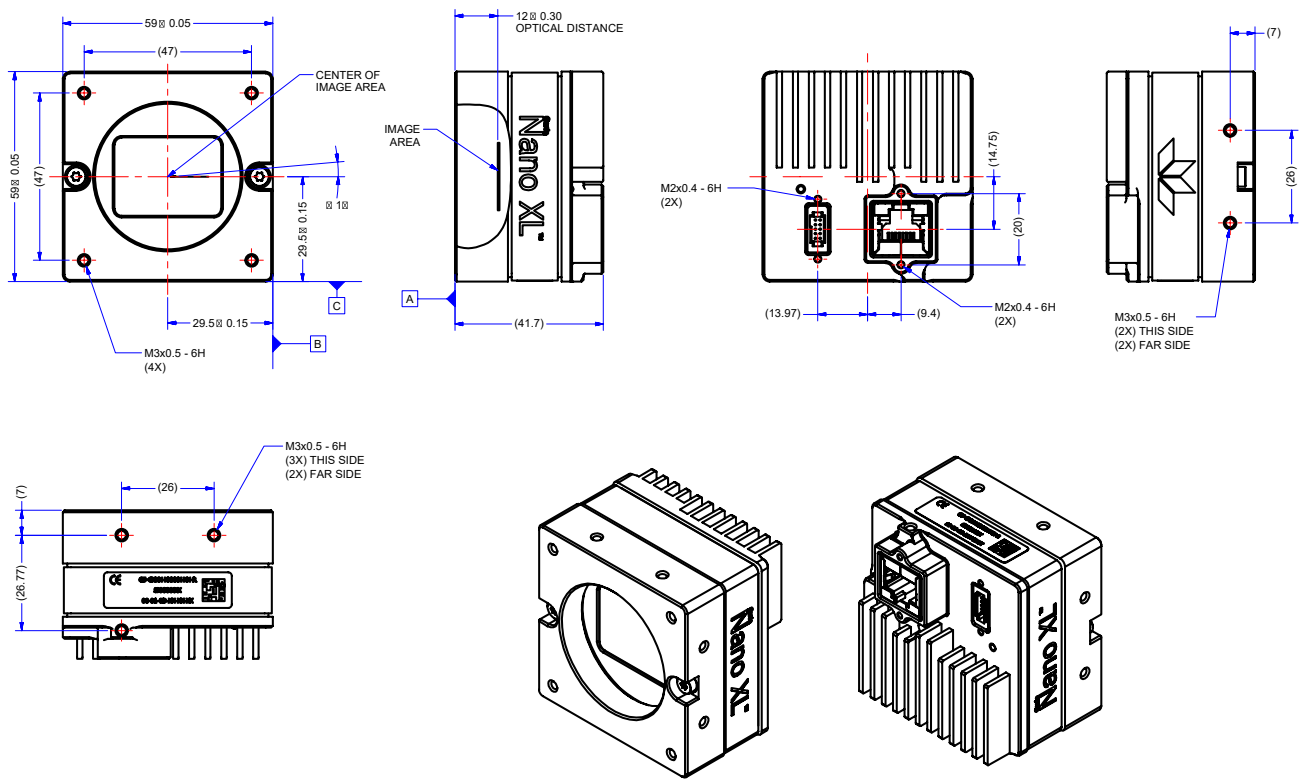
DRAWING OF P/N : G6-Gxxx-xxxx5

NOTES:
 1. UNITS: MILLIMETERS.
 2. IMAGE AREA IS ALIGNED TO DATUMS **A**, **B** & **C**.

FOR MORE INFORMATION CONTACT:

 945 East 11th Avenue Tampa, FL 33605

Phone: (813) 984-0125

Contact: Sales@pyramidimaging.com

<https://pyramidimaging.com>

This document does not contain information whose export/transfer/disclosure is restricted by the Canadian Export Control regulation. Teledyne DALSA has its corporate offices in Waterloo, Canada. Teledyne DALSA reserves the right to make changes at any time without notice. © 2022 Teledyne DALSA.

Revision Number: 07
 Revision Date: 2023 03 14