

8K FFL for Super 35mm sensor

Model	VS-HX3535
Focal Length (f)	35 mm (36.06)
Maximum Aperture Ratio	1: 3.5
Aperture	F 3.5 ~ F 16
Angle of View (Super 35mm)	27.6° × 41.1° (Diagonal: 49.9°)
M.O.D	330.4 mm
TV Distortion (Super 35mm)	-1.48 %
Operation	Manual (Lock screw M2)
Wavelength	Visible
Mount	M 52 P= 0.75
Flange Back	46.5 mm
Sensor Size (max.)	Super 35mm
Filter Thread	M 49 P= 0.75
Weight (approx.)	500 g
Dimension	ϕ 56 (max.) × L = 107.1 mm

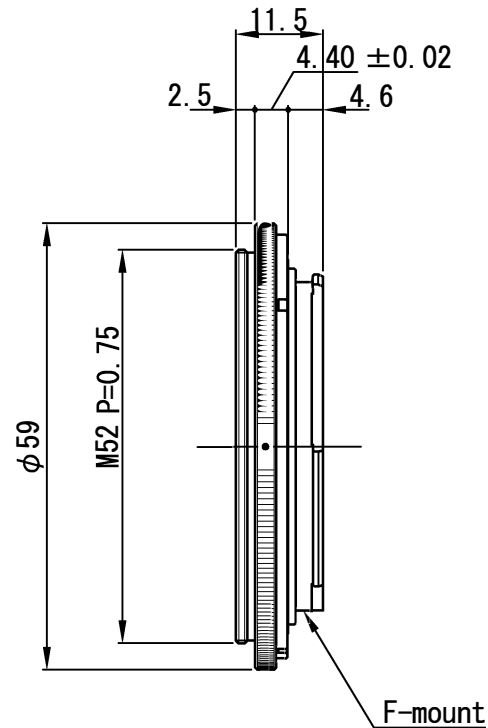

△×				APPROVED	CHECKED	MATERIAL 材料	-	CHAMFER 一般面取	-	QUANTITY 个数				
△×				T. A.	T. A.	TREATMENT 処理	-	FINISHING 仕上	-	-				
△×						TREATMENT CONTACT 処理接点	-	DECENTRATION 偏芯	-					
△×				DESIGNED	DRAWN	OVER 250 UP TO 1000	±0.3 ±0.5 ±1.0 ±0.2	ANGLE 角度	METHOD 図法	REMARK 適用 (機種名)				
△×				T. A.	T. T.	OVER 63 UP TO 250	±0.2 ±0.3 ±0.6 ±0.15	UNIT (mm)	-	VS - EXR 4 . 4 / F				
△×						OVER 16 UP TO 63	±0.1 ±0.2 ±0.4 ±0.1				SCALE	1 / 1	NAME	外觀圖
△×						OVER 0 UP TO 16	±0.05 ±0.1 ±0.2 ±0.1				DATE	'15.03.23	DRAW NO.	0 D A D 0 1 3 9 A 1
NO. × 箇所	REVISION 訂正事項	DATE	NAME	TOLERANCES		A	B	C	S					