

BOA PRO

Smart Vision System

Installation Manual



Notice

BOA PRO Vision System Installation Manual
Document Number 405-00031-00
Revision: 05a; 17 September 2014

Copyright © 2014 Teledyne DALSA Incorporated.
All rights reserved.

All copyrights in this manual, and the hardware and software described in it, are the exclusive property of Teledyne DALSA Incorporated and its licensors. Claim of copyright does not imply waiver of Teledyne DALSA Incorporated or its licensors other rights in the work. See the following Notice of Proprietary Rights.

NOTICE OF PROPRIETARY RIGHTS

This manual and the related hardware and software are confidential trade secrets and the property of Teledyne DALSA Incorporated and its licensors. Use, examination, reproduction, copying, transfer and/or disclosure to others of all or any part of this manual and the related documentation are prohibited except with the express written consent of Teledyne DALSA Incorporated.

The information in this document is subject to change without notice. Teledyne DALSA Incorporated makes no representations or warranties with respect to the contents of this manual and specifically disclaims any implied warranties of merchantability or fitness for a particular purpose. Teledyne DALSA Incorporated assumes no responsibility for errors or omissions in this document.

BOA, BOA PRO, iNspect, Sherlock, and the Teledyne DALSA logo are trademarks of Teledyne DALSA Incorporated. All other trademarks are the property of their respective owners.

Teledyne DALSA Industrial Products
Information: info.ipd@teledynedalsa.com
Support: support.ipd@teledynedalsa.com
Web: <http://www.teledynedalsa.com/ipd>

700 Technology Park Drive
Billerica, MA, USA 01821

Tel 1.978.670.2002 Fax 1.978.670.2010



Declaration of Conformity	
Manufacturer	Teledyne DALSA Corporation 605 McMurray Road Waterloo N2V 2E9 Ontario, Canada
CE	We declare that this product has been tested to comply with the EC Directive for a class A digital device in accordance with EN55022/CISPR22
FCC	We declare that this product has been tested and found to comply with the limits for a class A digital device, pursuant to Part 15 of the FCC rules. These limits are designed to provide reasonable protection against harmful interference in a residential installation. This equipment generates, uses and can radiate radio frequency energy and may cause harmful interference to radio communication.
Other	
IP67	This product meets the requirements for industrial applications that require IP67 wash down protection - requires fitted sealing lens cover and sealing plugs on unused connectors
CFR 21 Part 11	This product provides the tools needed for users to implement an auditing program that could be in compliance with CFR 21 Part 11. These tools include: <ul style="list-style-type: none"> • System software security (password login and access limits) • Time stamp information on data output.

Handling Precautions

Care should always be exercised when handling and operating your BOA Vision System. Even though the system is encased within a rugged, industrial enclosure, incorrect use or handling can result in damage to your investment. To prevent this, we recommend you avoid the following:

- Hot-plugging cables and devices. Be sure to shut the system down and remove power before connecting or disconnecting anything to it.
- Free-standing operation. It is advisable to mount the system properly to prevent it from falling accidentally. Mounting holes are provided on each side of the system.
- Operating the system in an environment outside of it's recommended operating conditions.

Electro Static Discharge

Avoid the damage that ESD can cause. Never expose the internal electronics to a potentially hazardous environment by opening the enclosure. Doing so may cause serious damage.

User Service Warning

This product has no field-replaceable components. Tampering with the unit will void the product warranty.

Warranty

Teledyne DALSA warrants the BOA Vision System against defects in materials and workmanship for a period of twenty four (24) months from the date of delivery. Teledyne DALSA and its representatives expressly disclaim any and all other warranties.

Your sole remedy shall be repair or replacement of the BOA Vision System product and associated optional components, provided that the defective product is returned within the warranty period.

If you need to return the BOA Vision System, you must contact the Teledyne DALSA representative who sold you the product. Do not return your product to Teledyne DALSA without prior authorization.

Teledyne DALSA assumes no liability for damages resulting from the use of this manual.



Introduction	Overview	6	
	Product Support	6	
	Components	7	
Installation	Connections	8	
	Cable Pinouts	9	
	Cable Configurations	10	
	Panel Link Module	10	
	Ethernet Only Setup	11	
	Ethernet and I/O Setup	12	
	Software	Getting Started	13
		Change Address Using iDiscover	13
iDiscover Utility		14	
Change Address Using a Browser		15	
Sherlock Embedded Server		16	
Firmware Upgrading		17	
Sherlock Embedded Client		18	
Sherlock Embedded Emulator		18	
Specifications		General Specifications	19
	Input Specifications	20	
	Output Specifications	21	
	Output Control	22	
	Panel Link Specifications	23	
	PL-100 Wiring	24	
	PL-200 Wiring	26	
	Serial Port Connection	27	
	BOA Mechanicals	28	
	PL-100 Mechanicals	29	
PL-200-IO Mechanicals	30		

BOA PRO Vision System Overview

BOA vision system is the hardware platform. Sherlock Embedded is the powerful and flexible professional machine vision software. Together they are the BOA PRO.

BOA PRO is a fully integrated vision system in a compact “smart” camera format that has been specifically designed for industrial use. Packaged complete with application software embedded, BOA PRO provides power and flexibility for automated inspection for the factory floor.

BOA PRO vision systems are configured and monitored remotely using an Ethernet connection to a PC or factory network. An inspection can be quickly setup using the Sherlock Embedded Client Software application to access the programming interface. The software interface is fully equipped with a suite of image processing tools and capabilities that satisfy a range of needs.

BOA vision systems are small, rugged devices that can be easily integrated into existing production lines, machinery or moving equipment. They are supported by standard industrial M12 cordsets to further simplify and reduce implementation costs. Rated for IP67 deployment when fitted with a compatible lens cover, BOA systems can be mounted in wash down factory environments without the need for additional protective enclosures.

For a complete list of specifications, refer to “Specifications” on page 19.

Product Support

In addition to this installation manual, the following information ships with the product:

1. Online help: Fingertip help is available from the Sherlock Embedded Client Software
2. Sherlock Embedded Software Manual, Tutorial, and “How Do I?” documents are included on the CD that ships with the product
3. Factory support is available at support.ipd@teledynedalsa.com
4. Call, fax or email your local representative who sold you the product

BOA PRO Vision System Components

BOA PRO vision systems are shipped with the components listed below. Take a few moments to verify that everything has arrived in good condition. If your product has been visibly damaged during shipment or is missing parts, please contact your Teledyne DALSA representative immediately.

Standard components (ship with every BOA Vision System):

Component	Description
<u>BOA PRO Vision System</u> BVS50-0640X-PRO or, BVS50-1024X-PRO or, BVS50-1280X-PRO or, BVS50-1600M-PRO	BOA PRO Vision System. Fully integrated vision system with 640x480, 1024x768, or 1280x1024 monochrome or color sensor, 1600x1200 monochrome sensor, processing engine, Sherlock Embedded Server software, communications and light control. (X; M=mono, C=color)
BVS-PRO-CD	BOA PRO CD-ROM including the Sherlock Embedded Client software and associated product manuals and documentation.
Mounting Screw Kit	M4 screws for mounting the sensor (Qty 4)

Optional components (sold separately):

Component	Description
<u>Cables</u> A-BVS-E8S-X A-BVS-IO8S-X A-BVS-L5S-X A-BVS-PL8S-5 A-BVS-PL5S-5	M12-RJ45 Ethernet cordset (X; 5=5m, 10=10m) M12 single-ended IO cordset (X; 5=5m, 10=10m) M12 single-ended lamp cordset (X; 2=2m, 5=5m) M12 I/O connector to PL-200 cable 5m M12 Lamp connector to PL-200 cable 5m
BVS-PL-100	Panel Link breakout module. Provides Ethernet power and convenient panel access to BOA I/O.
BVS-PL-200 -E, -IO, -EIO	Panel Link breakout modules with extended I/O capability.
A-MB-BVS-0	Right Angle mounting block with 8 M4 screws.
Lens	Various Lens options available from DALSA.
A-BVS-LCG-X	Lens cover for BOA Vision System. Required for IP67 compliance. (X=35, 40 or 45 mm internal lens length).
A-BVS-LSS-F A-BVS-M12-P	Set screws for Fujinon Lens M12 plug for IP67 compliance
Lights	Various Lighting options available from Teledyne DALSA.

Connecting the BOA Vision System

This section details how to connect the BOA vision system with its associated components and factory environment.

Camera Connectors and Indicators

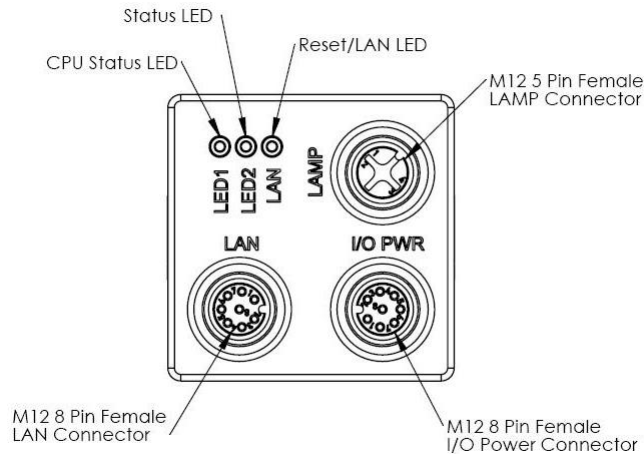

Designator	Definitions
LAN	10/100 BaseT Ethernet connection. Provides the primary interface for configuring the camera, developing the application and monitoring results. NOTE: The camera can be powered from the Ethernet cable directly (Passive Power over Ethernet)
I/O PWR	Provides access to the camera I/O – 2 IN, 2 OUT Opto. Also provides PWR input (12-30V). BEWARE: The LAN and I/O PWR connectors are identical but the power pins are different. Damage to the camera will result if you swap these cables!
LAMP	Provides PWR and strobe control to a local LED light source. NOTE: The power is common to all 3 connectors. The camera should be powered from a 12V PWR source if the light requires a 12V supply (Recommend 24V supply) See page 10.
LAN LED	Red/Green/Yellow = Network activity Blue = Warm Reset
LED2	Blue blink = Booting (stops after about 20 seconds) Off = Program not loaded or pass/fail unknown (not run, or new) Green Solid = Inspection Passed Red = Inspection Failed
LED1	Off = Starting/booting Blue Solid = Program not loaded, not configured, or unsaved Green Solid = Program configured, loaded, or saved





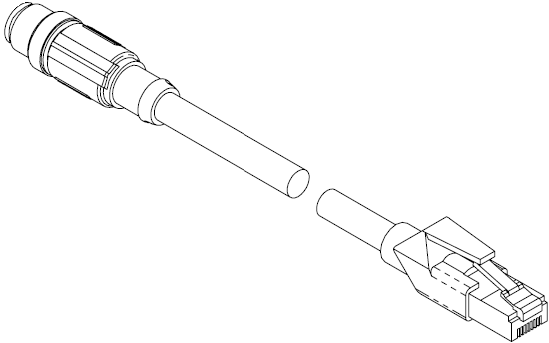

Cable Pinouts

The BOA vision system is compatible with M12 factory cordsets as show below:

LAN Connector Pinout and Cordset			
Pin	Name	RJ45 Pin	
1	PWR *	5	
2	NC	7	
3	GND *	8	
4	TXD-	2	
5	RXD+	3	
6	TXD+	1	
7	NC	4	
8	RXD-	6	





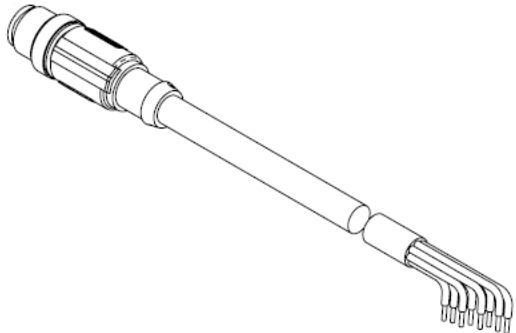

A-CAB-BVS-E8S-X

I/O-PWR Connector Pinout and Cordset			
Pin	Name	Color	
1	TRIG		White
2	PWR		Brown
3	IN0		Green
4	OUT1		Yellow
5	IN CMN		Gray
6	OUT0		Pink
7	GND		Blue
8	OUT CMN		Red



A-CAB-BVS-IO8S-X

LAMP Connector Pinout			
Pin	Name	Color	
1	PWR		Brown
2	RS232 RX		White
3	GND		Blue
4	STRB		Black
5	RS232 TX		Gray

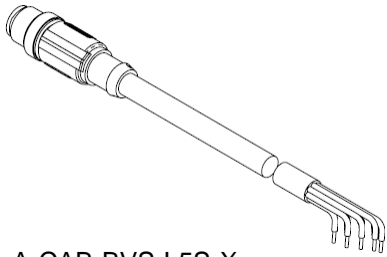

A-CAB-BVS-L5S-X

* For Passive Power over Ethernet

Cable Configurations

The BOA vision system offers flexible cabling options to suit a number of application configurations:

1. For single cable applications, the Ethernet cable can be used to supply power (referred to as “Passive Power over Ethernet”) and communications between the camera and the control environment. Power is supplied by connecting a DC voltage source between 12-30V to conductors 4 (pwr) and 8 (gnd) on the Ethernet RJ45 connector. **Note: The PL-100 module does this automatically. In this configuration, the camera I/O is unavailable.**
2. For single cable applications that do not require a runtime Ethernet connection, the I/O-PWR cable provides limited communications and power between the camera and the control environment. **Note: Ethernet is still required for setup.**
3. For typical applications, both the Ethernet and I/O-PWR cables are connected to provide flexibility between the camera and the control environment. In this configuration, either or both cables can supply power provided they come from the same power source. Do not connect different power sources to the BOA camera connectors. **Power is common to all three connectors.**
4. In all configurations, the Lamp cable can be connected between the camera and a compatible LED light source. The BOA vision system supplies power and strobe control to the external light. Power is routed from camera power input to the lamp.

BEWARE: Connecting a voltage on pin 1 of the lamp connector that is lower than the input power voltage to BOA could result in damage to the camera!

The LAN and I/O PWR connectors are identical. Do not swap these cables. Damage to the camera will result!

Panel Link Module (A-BVS-PL-100)

The PL-100 module is an optional module that provides a safe and convenient way to interface BOA. It provides an isolation layer between the factory and the camera (differential isolation), as well as supplying power via the Ethernet cable for single cable applications. The PL-100 also provides a manual trigger button and status lights for application debug.

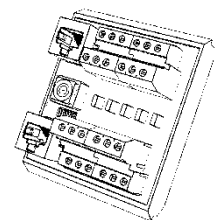

A-BVS-PL-100

NOTE: The BOA vision system does not support the IEEE 802.3af standard Power over Ethernet (PoE) and should not be directly connected to a PoE supported router.

Ethernet Only Setup with Lamp

1. Connect the M12-8 male end of the Ethernet cordset (A-BVS-E8S-X) to the M12-8 female connector labeled “LAN” on the camera.
2. Connect the RJ45 end of the Ethernet cordset to the RJ45 connector labeled “CAM LAN” on the Panel Link breakout module (A-BVS-PL-100)
3. Connect the RJ45 labeled “LAN” on the breakout module to the controlling PC, PLC or the factory LAN
4. Connect camera PWR and GND to the breakout screw terminals labeled “PWR”
5. Connect the Lamp via corset A-BVS-L5S-X between the camera (M12-5 and the lamp)

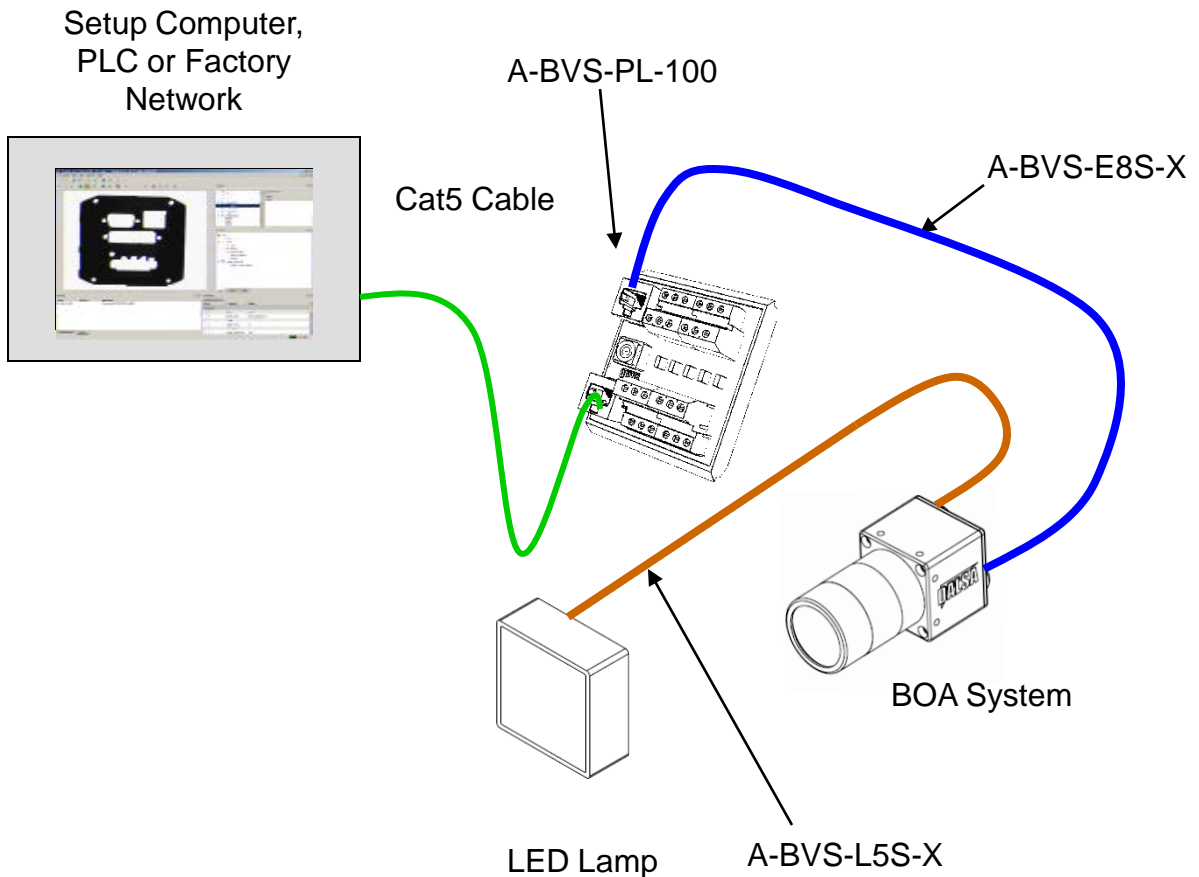

Ethernet and I/O Setup with Lamp

1. Connect the M12-8 male end of the Ethernet cordset (A-BVS-E8S-X) to the M12-8 female connector labeled "LAN" on the camera.
2. Connect the RJ45 end of the Ethernet cordset to the RJ45 connector labeled "CAM LAN" on the Panel Link breakout module (A-BVS-PL-100)
3. Connect the RJ45 labeled "LAN" on the breakout module to the controlling PC, PLC or the factory LAN
4. Connect camera PWR, GND and I/O from the control panel to the breakout screw terminals.
5. Connect the M12-8 male end of the IO-PWR cordset (A-BVS-IO8S-X) to the M12-8 female connector on the camera labeled "I/O PWR"
6. Connect the open-ended wires of the IO-PWR cordset to their respective connections on the breakout module.

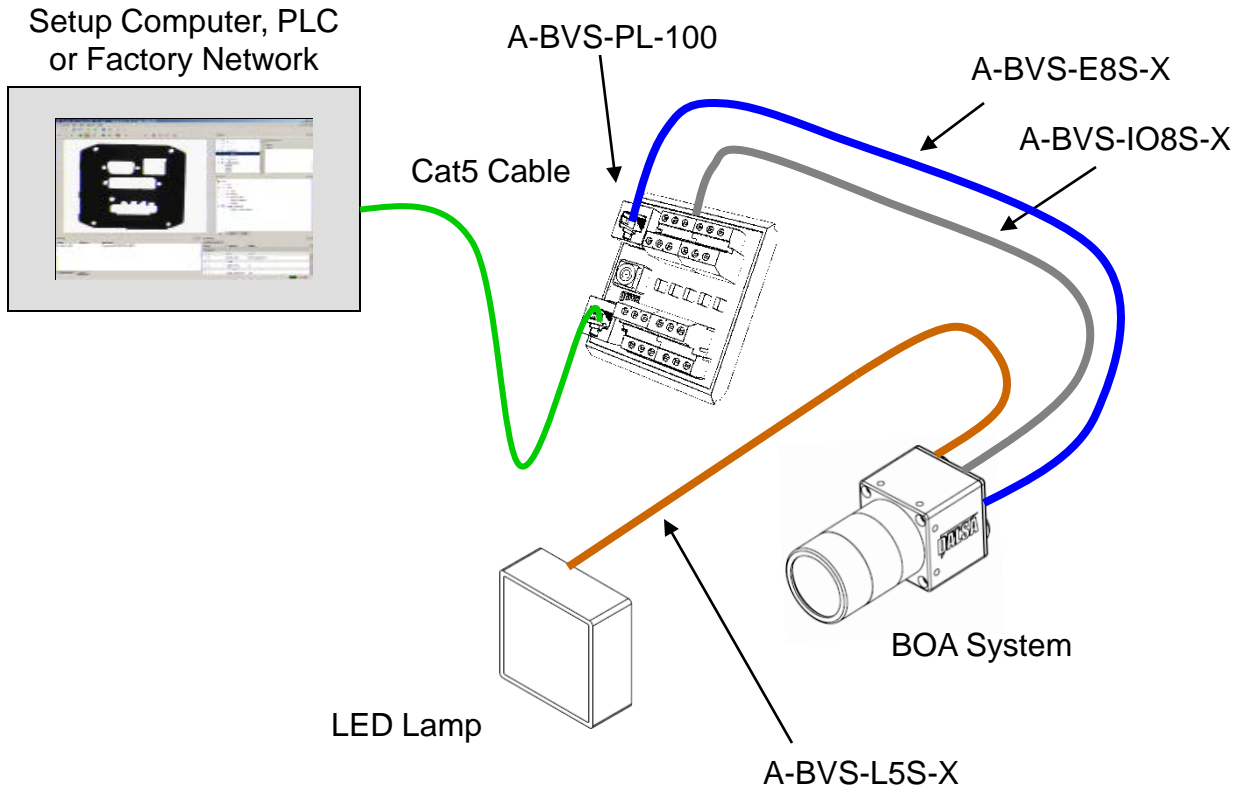

BEWARE: The LAN and I/O PWR connectors are identical. Do not swap the cables. Damage to the camera may result.

Getting Started

The BOA PRO vision system is supplied with the Sherlock Embedded application embedded. This application offers an advanced suite of vision processing capabilities to satisfy a diverse range of automated inspection needs. The application interface is accessed through the Ethernet connection using a PC with the Sherlock Embedded Client software application.

- You **do not** need to install software on a PC to monitor the BOA PRO system.
- You **do** need to install the Sherlock Embedded Client Software to program and configure the BOA PRO system.

Take note of the following before attempting to access the application:

BOA PRO vision systems are preconfigured with a default static IP address of **192.168.0.100**. Most applications will require changing this address to be compatible with a local machine network. There are two ways to change the BOA PRO address: using the iDiscover utility, which is installed with the Sherlock Embedded Client software, or using an Internet Browser (no software installation needed).

Change the Address Using the iDiscover Utility

The iDiscover utility is provided for discovering BOA cameras connected to the local PC network. iDiscover is installed on the Client PC with the Sherlock Embedded Client Software. The iDiscover program can also be run from the CD-ROM, in the Utilities directory:

1. Insert the BOA PRO CD into your PC's drive. The installation utility should start automatically. (On Windows 7 you may be asked if you wish to run the setup.exe utility or open windows explorer.)
2. Click "Install Software" to begin the installation. The Sherlock Embedded Client software will be the default selection. You will be asked to confirm the destination directory.

After the Client software is installed, iDiscover can be launched in one of two ways:

- a) Open the command prompt ("Start -> Run"), use the "Browse" button to navigate to: "Program Files/Teledyne DALSA/Sherlock Embedded/Utilities/iDiscover.exe" and click "OK" in the Run dialog.
- b) Use Windows Explorer to navigate to: "Program Files/Teledyne DALSA/Sherlock Embedded/Utilities" and double-click on "iDiscover.exe".

iDiscover Utility

Once launched the GUI below will be shown. The left panel shows the MAC addresses of all reachable and non-reachable BOA cameras. If a camera icon is blue, the address is compatible. If the camera icon is red, the address is not compatible. Click on one of these to populate the associated network configuration on the right. You can then modify the BOA IP address, and click “Apply”.

The “Connect To Device” button will launch Internet Explorer and connect to the BOA PRO home page (IE6 is not supported).

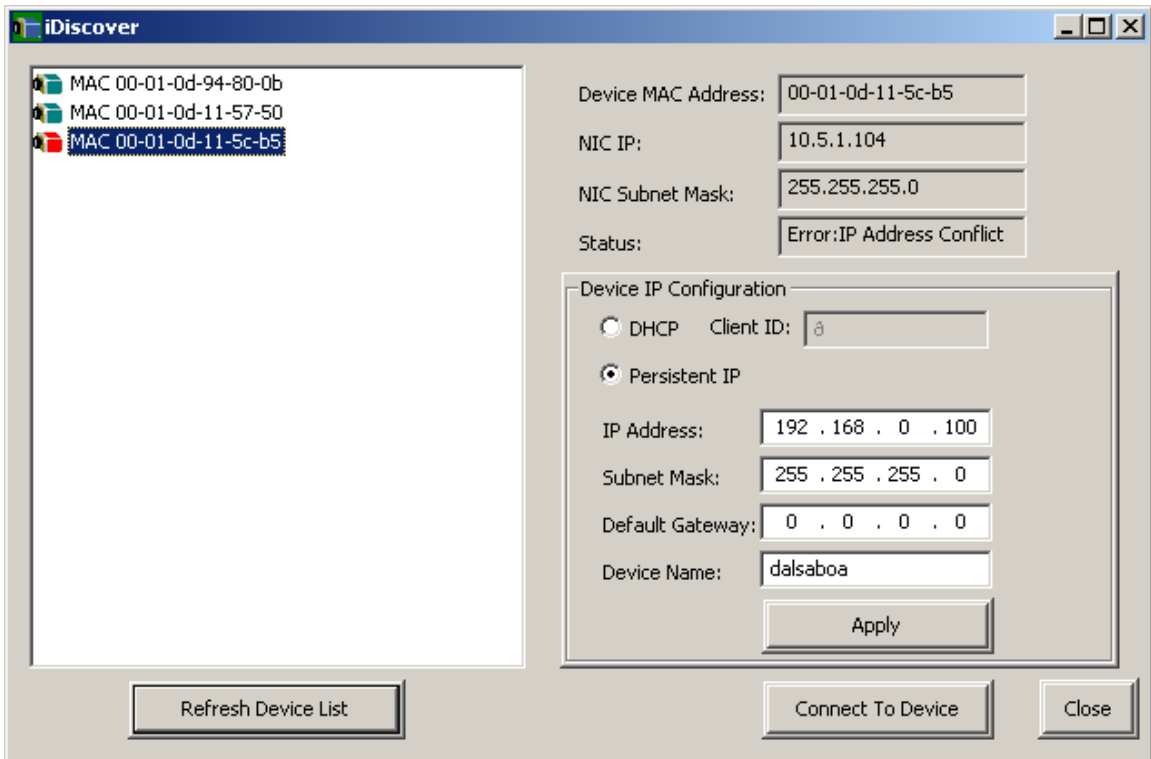

In most cases you will need administrator privileges on your PC to access BOA. It may be necessary to customize the security settings on your browser.

NOTE: See the document “Configuring Windows for BOA” on the BOA PRO CD-ROM.

Change the Address Using a Web Browser

The BOA static IP address can be changed through the Sherlock Embedded Web Server interface to match your Local Area Network. BOA is compatible with host computers running the Windows XP, Vista and Windows 7 operating systems. The following browsers have been tested: Microsoft Internet Explorer version 8, Mozilla Firefox 5.0.1, Google Chrome 13.0.782.220.

1. The PC used to access BOA initially will need to be configured on the same network neighborhood, but with a different address (i.e. 192.168.0.101). Consult your system administrator for instructions on how to do this. The subnet mask should be set automatically to 255.255.255.0. **NOTE: Write down or capture the PCs original network address settings before making any changes.**

2. Launch your web browser, and type the BOA PRO address in the address bar. The factory default address is: 192.168.0.100.

3. Hover on “Device” and select “Network Setup” to change the network address or name. BOA supports both DHCP and Static IP addressing. Static is usually preferred since the address does not change.

NOTE: A power cycle is required before the new address or name will take effect.

4. Close your web browser. Change the network settings back to their previous settings. Usually you do not need to reboot a PC after changing the network addressing.

If you incorrectly set, or forgot, the new address of your BOA PRO, you can run the “iDiscover” utility. This utility is installed automatically when you install the Sherlock Embedded Client software on a PC.

In most cases you will need administrator privileges on your PC to access BOA. It may be necessary to customize the security settings on your browser.

NOTE: See the document “Configuring Windows for BOA” on the BOA PRO CD-ROM.

Sherlock Embedded Web Server

The Sherlock Embedded Web Server is a portal through which the BOA PRO vision system can be Monitored when running or inspecting. This interface is also used for upgrading the BOA PRO firmware. The web server is accessed from a host PC using a Web Browser. The following browsers have been tested: Microsoft Internet Explorer version 8, Mozilla Firefox 5.0.1, Google Chrome 13.0.782.220.

1. Open the web browser on an address compatible PC connected to the camera
2. Enter the URL address of the camera in the address bar and press Return.
3. The camera web server interface will be displayed in the browser as follows:

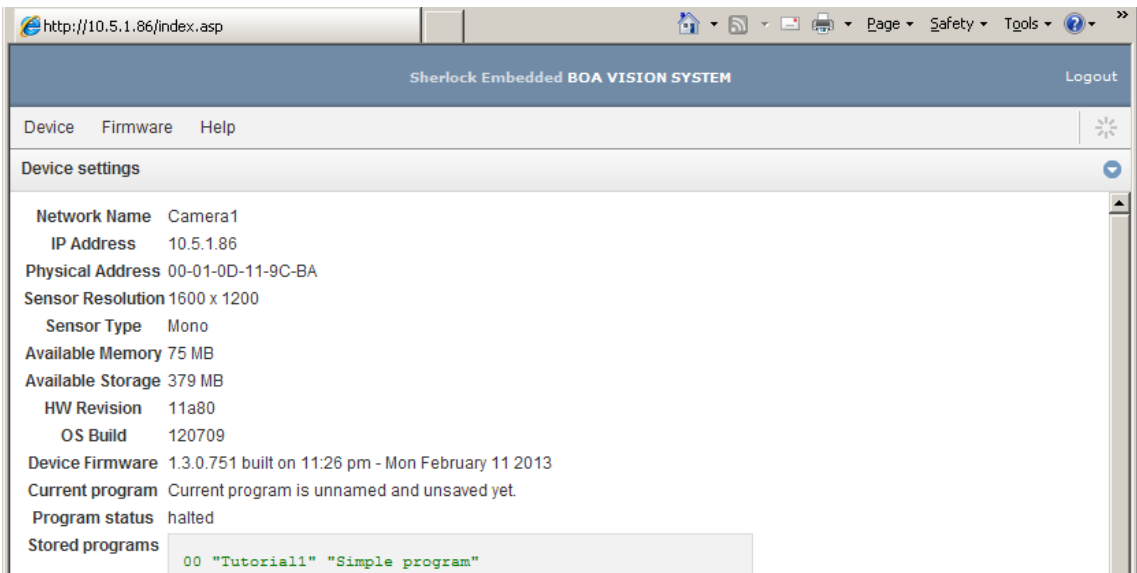

4. The web server provides a quick snapshot of the state of the camera and provides controls for Monitoring a running inspection, IP address setup, firmware upgrading, and a command console. The web server can be password protected to prevent unauthorized access. The Monitor page can be accessed without a password.
5. The web server interface is not password protected in the factory configuration, and is always logged in by default. If you click on “logout” only the “Run Monitor” and “Device info” pages are available when not logged in. If you have not added a password, click “login” to access the other pages.
6. Click on “Device” then select “Change password” to add password protection to the web server interface. NOTE: This is separate from the password protection on the Client Software interface. Remember the password! This cannot be reset.

When the application is set up and stored on the camera, the Ethernet connection can be disconnected and the inspection will run autonomously (if power is supplied on the IO connector).

The camera can easily store over 50 inspection programs in its flash storage memory. These programs can be switched through network commands, or through established PLC register connections or through the iNSpect application interface.

The camera administrator can setup user accounts with various levels of access privilege. With password control enabled, the web server will prompt users for a valid login and the application will only expose controls associated with that account.

Firmware Upgrading

Note: Export your saved inspection program files before upgrading the firmware.

BOA PRO firmware may need to be updated occasionally to add new features or fix reported problems. To do this, click on “Firmware” then select “Update Firmware”. To upgrade, simply browse to the location of the upgrade binary file “update.pak” (obtain from your Teledyne DALSA representative) on the connected PC and click the upgrade button.

After a firmware upgrade, it is recommended that the programming PC be upgraded to a version of the Client software that matches the new firmware version. The new Client software should be obtained at the same time as the firmware update file. The two software packages are build together, and should have the same date and time.

Uninstall the current version of the Sherlock Embedded Client, using the Windows “Add and Remove Programs”. Reboot the PC, and install the newer version that matches the firmware you just installed.

Sherlock Embedded Client

The Sherlock Embedded Client Software is used to program and configure the inspection and peripheral communications. The Sherlock Embedded Client software is available on the CD that ships with the camera and is very easy to install.

1. Insert the BOA PRO CD into your PC's drive. The installation utility should start automatically. (On Windows 7 you will be asked if you wish to run the setup.exe utility or open windows explorer.)
2. Click "Install Software" to begin the installation. The Sherlock Embedded Client software will be the default selection. Click "Start Install". You will be asked to confirm the destination directory.

If security settings prevent the CD from running the install utility, you can navigate to the "SherlockEmbeddedClient" directory. In Windows 7, right-click on "SherlockBOA.exe" and click on "Run as Administrator". In Windows XP, double-click on "SherlockBOA.exe".

A Software Manual, Tutorial, and other documents are included on the BOA PRO CD. The Sherlock Embedded Tutorial gives a very easy-to-follow tour through the Client software interface and many programming features. ***It is highly recommended that you read and follow the Sherlock Embedded Tutorial to gain familiarity with the programming interface for the Sherlock Embedded software.*** Many features of the interface are introduced and explained in this document. Several explanations and tips are included.

The on-line Help "How To" section covers some more advanced topics and solutions. Some topics include step by step instructions, and some are in more general terms.

NOTE: The Sherlock Embedded Client interface can be password protected to prevent others from opening the Client interface. This is separate and different from the password protection on the web server interface. Do not forget the password! This cannot be reset.

Sherlock Embedded Emulator

The Emulator software is installed automatically with the Sherlock Embedded Client software. The Emulator provides a way to demonstrate the Sherlock Embedded software capabilities, or experiment off-line with a sequence of images.

You may not use the Sherlock Embedded Emulator software in a production environment.

General Specifications

This following table lists the specifications of the BOA vision system:

Specification		Definition
Memory	Storage	512MB Storage (flash); 256MB Program (RAM)
Image	Sensor	1/3 inch CCD; 7.4 μm pixel size
	Resolution	640x480, 1024x768, 1280x1024
	Type	Monochrome Progressive Scan
	Exposure	22 us to 1000 ms (range depends on the camera resolution)
	Acquisition	Async Reset, full-frame integration, maximum 60f/s with 640x480
	Lens	C Mount
I/O	Trigger	1 opto-isolated hardware trigger input
		Software trigger via Ethernet or internal timer
	Inputs	1 General purpose opto-isolated.
		Expandable via PL-200 I/O module
	Outputs	2 General purpose opto-isolated
		Expandable via PL-200 I/O module
Strobe	1 dedicated strobe output for LED light source	
Status	Network + 2 application assigned LEDs	
Network	Ethernet	10/100 BaseT
Serial	RS232	1 Port – flying leads on lamp connector
Power	12-30V	Via Ethernet or IO connectors (not PoE compliant)
	Device (BOA)	150 mA maximum @ 24V (3.6 Watts)
	Lamp PWR	1A maximum (BOA powering light source directly, pin 1)
Mechanical	Material	Machined Aluminum with anodize/paint finish
	Mounting	8 x M4 plus optional mounting block
	Size	44mm x 44mm x 56mm (without lens cover)
Environment	Temp	-10°C (14°F) to 50°C (122°F) Operating (-60°C to 80°C) Storage
	Protection	IP67 with cables attached
	Shock	70 G
Certification		FCC Class A and EU CE

Input Specifications

The BOA PROvision system provides two dedicated opto-isolated, polarity independent inputs. One of the inputs provides the acquisition Trigger function, while the other is general purpose.

Specification		Definition
Voltage	ON	12-30 V
	OFF	0-3 V (12 V nominal threshold)
Current	ON	7.5 mA typ (24 V applied)
Protection	Resistance	3K Ohms
	Isolation	4000 V RMS
Common pin	Input	PWR or GND
Switch Time	ON	10 Microsecond
	OFF	50 Microseconds
Latency	Trigger	62 Microseconds from trigger input to start of acquisition

The active polarity of each input is configured in the Sherlock Embedded Client application. The camera includes a noise filter on the input which is also configurable.

To connect with an NPN source, connect the camera trigger input (pin 1) to the NPN source output and the camera common input (pin 5) to PWR. When the source output turns ON, the camera input will be pulled down turning the opto-coupler ON.

To connect with a PNP source, connect the camera trigger input (pin 1) to the PNP source output and the camera common input (pin 5) to GND. When the source output turns ON, the camera input will be pulled up turning the opto-coupler ON.

Input Diagram

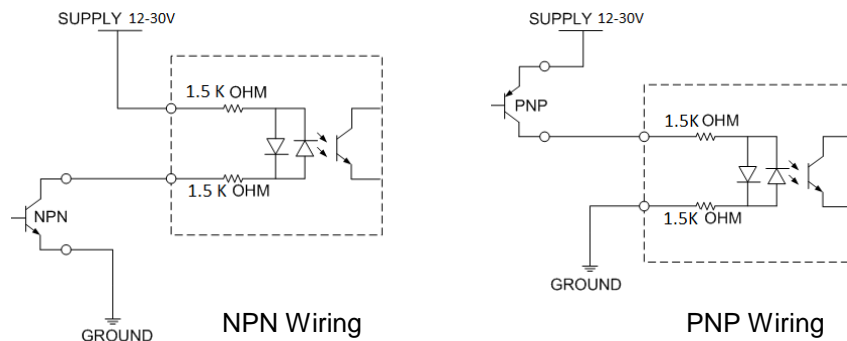

Output Specifications

The BOA PRO vision system provides two dedicated opto-isolated, solid state relay outputs and a separate dedicated light strobe (pin 2 of lamp connector).

Specification		Definition
Voltage (Vin)	Load	24V maximum
Current	GPO[0:1]	100mA max (drives to OCMN when active)
	STRB	100mA max (drives to Vin when active) Lamp connector pin 4 NOTE: Strobe timing is configured in the "Cam0" properties.
Protection	Fuse	PTC fuses to 100mA (GPO) & 100mA (STRB)
Common pin	Out	PWR or GND
Switch Time	ON	10 Microsecond
	OFF	50 Microseconds

The active polarity of each output is configured in the Sherlock Embedded Client application.

To connect with an NPN input source, connect the camera output (pin 4 or 6) to the NPN source input and the camera common output (pin 8) to GND. When the camera output turns ON, the opto switch closes and OUTX = 0 (current flows through load)

To connect with a PNP input source, connect the camera output (pin 4 or 6) to the PNP source input and the camera common output (pin 8) to PWR. When the camera output turns ON, the opto switch closes and OUTX = output common.

Output Diagram

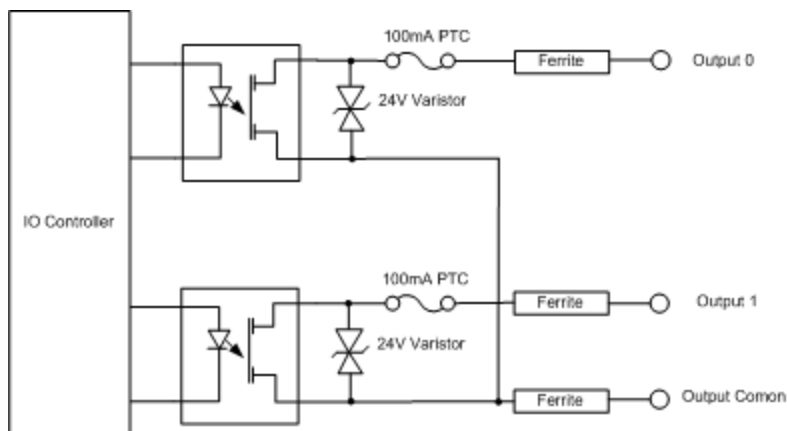

Output Control with Sherlock Embedded

The Sherlock Embedded application provides programmable options for controlling the outputs on the BOA PRO. The timing and polarity of the outputs is controlled in Digital IO Instructions. Each individual output can be controlled by an instruction in the Program Window (as detailed in the Sherlock Embedded Tutorial). The following instructions are available:

set_io – Sherlock Embedded sets an output in a steady state.

pulse_dig_io – Sherlock Embedded sends the pulse command to the hardware, and waits for the pulse to complete. This makes the program execution wait at least the pulse duration time before going to the next statement.

async_pulse_dig_io – Sherlock Embedded sends the pulse command, and continues to the next statement without waiting. The pulse begins almost immediately, with minimum wait time.

schedule_async_pulse_dig_io – Sherlock Embedded sends the pulse command with a delay count, and continues to the next statement without waiting. The pulse delay count begins almost immediately, and the pulse begins at the end of the delay count.

PL-100 Specifications

The PL-100 module offers additional isolation for the BOA PRO camera and simplifies wiring at the control panel. The module also provides power over Ethernet for single cable applications.

I/O connections to the BOA PRO camera should be wired to the TOP connectors on the PL-100 (J2 and J3) directly. **NOTE: Avoid reversing PWR/GND on the I/O connector. Doing so may make the PoE feature unusable. In this case power must always be supplied through the IO cable.**

I/O connections in the control panel (outside world) should be wired to the BOTTOM connectors on the PL-100 (J5 and J6). Specification for these signals are as follows:

Specification		Definition
Voltage	Load	24V maximum
Current	GPO[0:1]	100mA max
Protection	Fuse	PTC fuses to 100mA (GPO)
Common	ICMN/OCMN	PWR or GND as wired on respective OPTOs
Switch Time	GPO[0:1]	100 Microsecond (ON or OFF)

PL-100 Connections

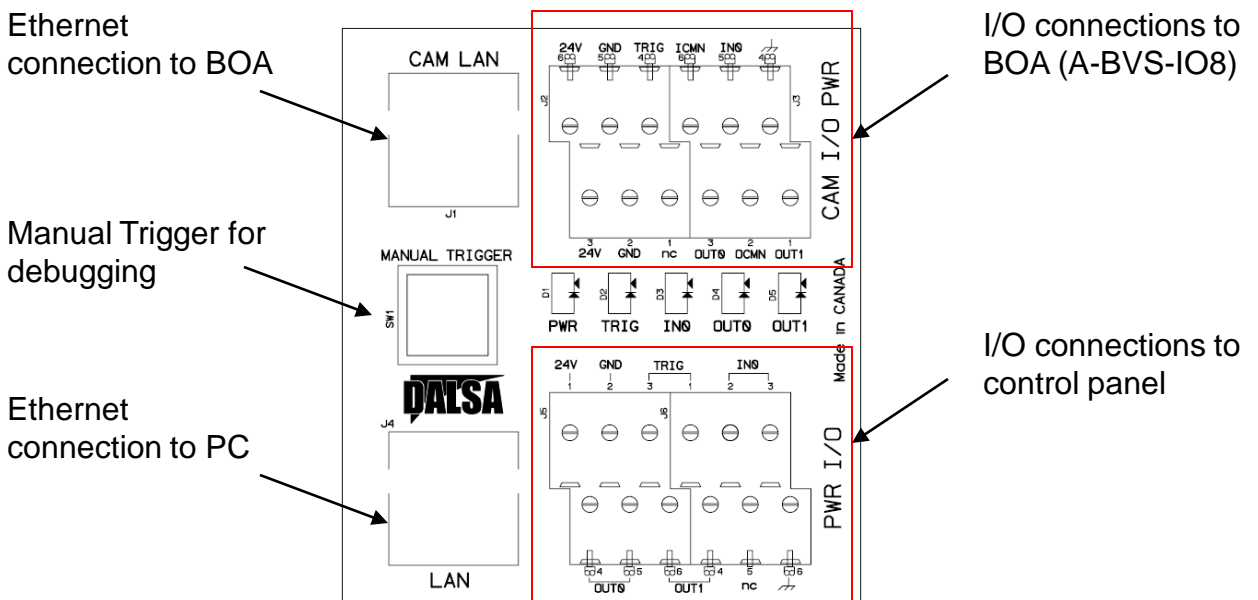

PL-100 Wiring

Note: BOA side is a 1:1 connection using A-BVS-IO8S

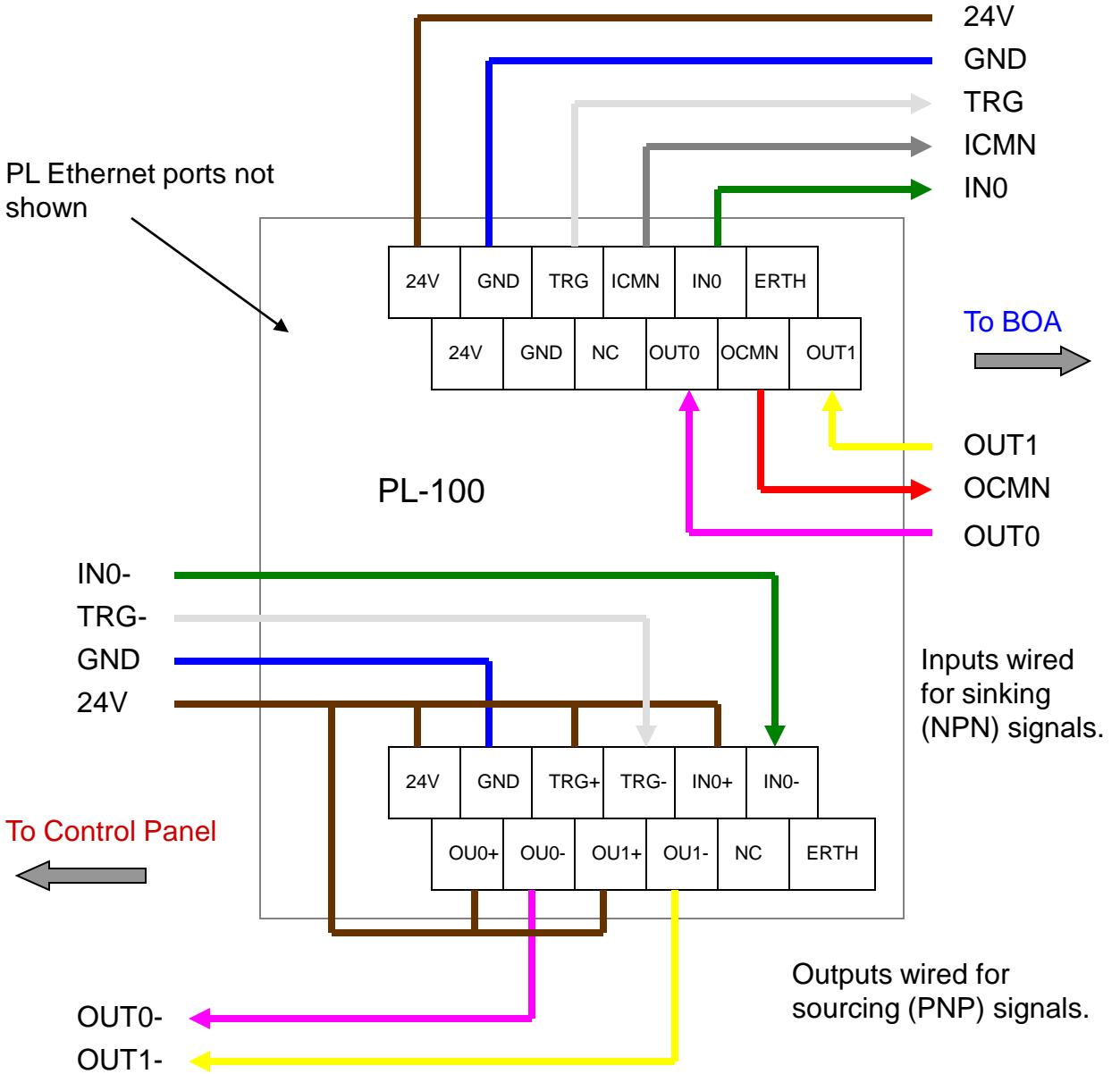

Note: Cable color code on panel side is user defined.

PL-100 Wiring

Note: BOA side is a 1:1 connection using A-BVS-IO8S

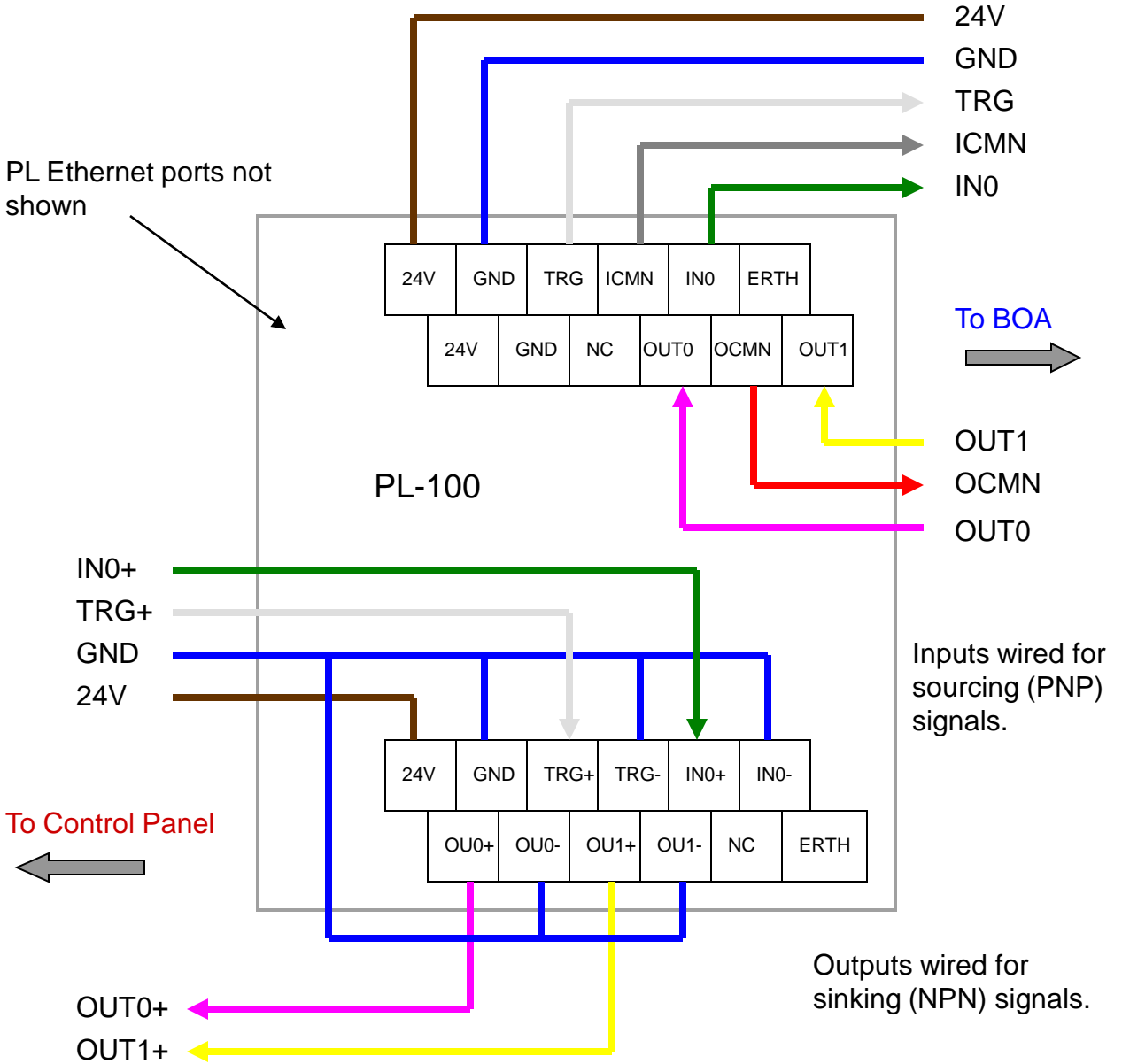

Note: Cable color code on panel side is user defined.

PL-200 Wiring

The following diagram shows where to connect PWR (brown) and GND (blue) wires for a typical PNP hookup. **See PL-200 manual for more detailed information.**

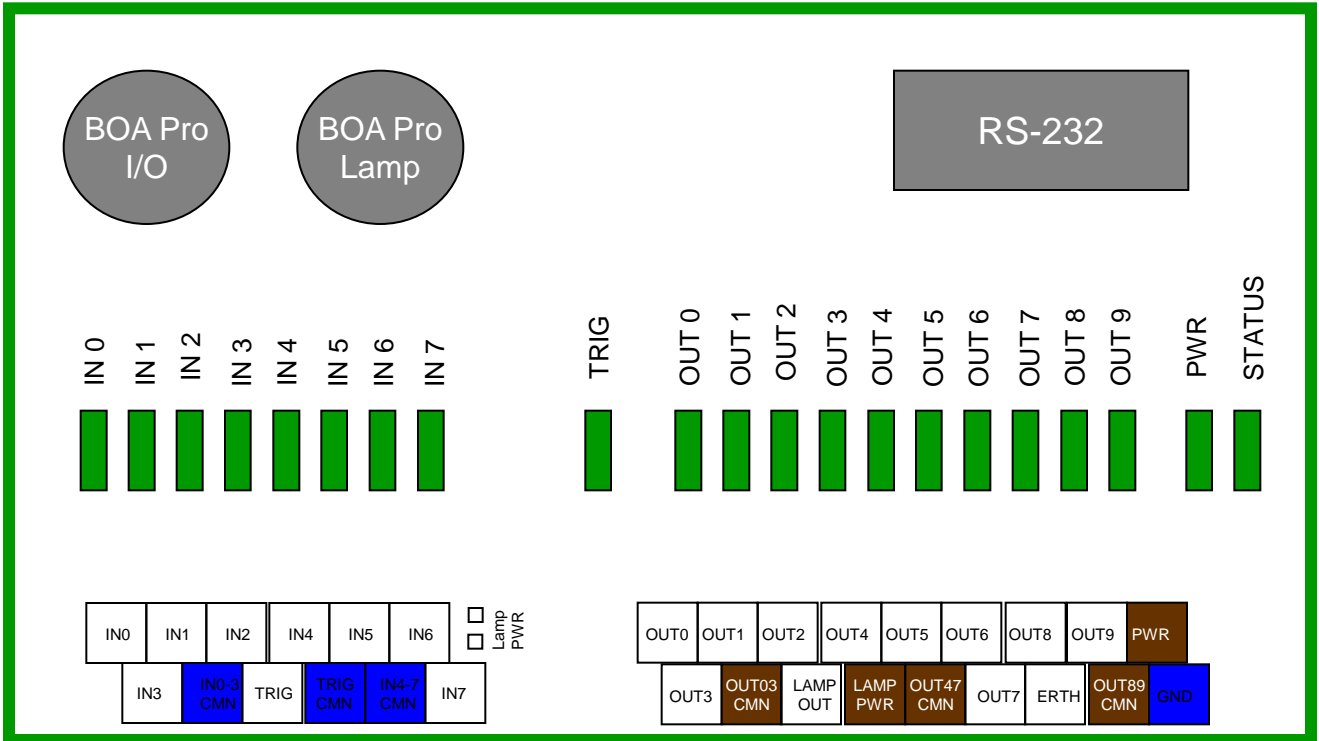

With the input common lines grounded, a valid signal will be detected if the selected input line transitions beyond the input voltage threshold (12.5V min).

With the output common lines set to PWR, the outputs will transition to the PWR state under program control.

POWER Specification

Parameter	Value
Power Input Voltage	24V Nominal (12V Min / 30V Max)
Power Input Current at 24V	0.03A – No camera connected 0.19A – One BOA camera connected and running (*)
Input Protection (**)	- Protected against polarity inversion by schottky diode - Current limiting at 1.5A by PTC fuse - Overvoltage protection at 33V by varistor and TVS diode - Inrush current limiting controller (hot-swap switch)

Serial Port Connection



The RS-232 serial port is accessible through the Lamp connector. By default, the serial port settings are set as follows:

Port definition	Setting
Baud Rate	115200
Data Bits	8
Parity	None
Stop Bits	1
Flow Control	None

These port settings can be changed through the GUI by configuring the “Serial Port Properties” in the Sherlock Embedded Client application. Refer to the online Help for details.

RS-232 Hardware Configuration

Electrically, three (3) signals are required to make a serial port connection between BOA and another device as shown below. RS232 is a “point-to-point” connection, so the Receive and Transmit lines must be crossed in the cable.

BOA LAMP M12-5 Connector			
Pin	Name	Color	
2	RS232 RX		White
3	GND		Blue
5	RS232 TX		Gray
1,4	Not required		

3 rd Party DSUB-9 Connector	
Pin	Name
3	TX
5	GND
2	RX
1,4,6,7,8,9	Not required

Note: It is important to establish a common ground between BOA and the connecting 3rd party device.

BOA Mechanical Dimensions

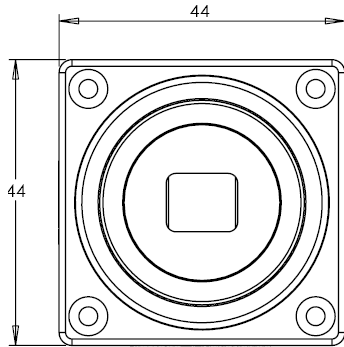

Front View

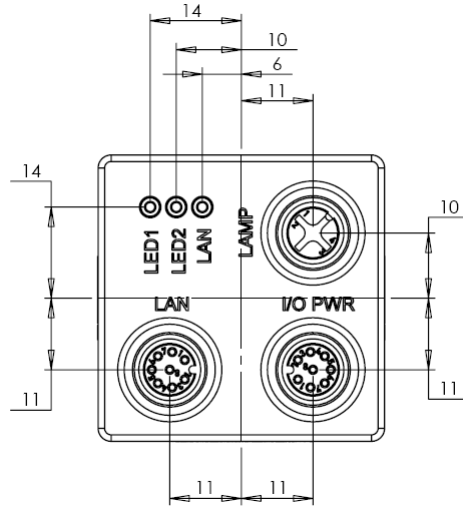

Back View

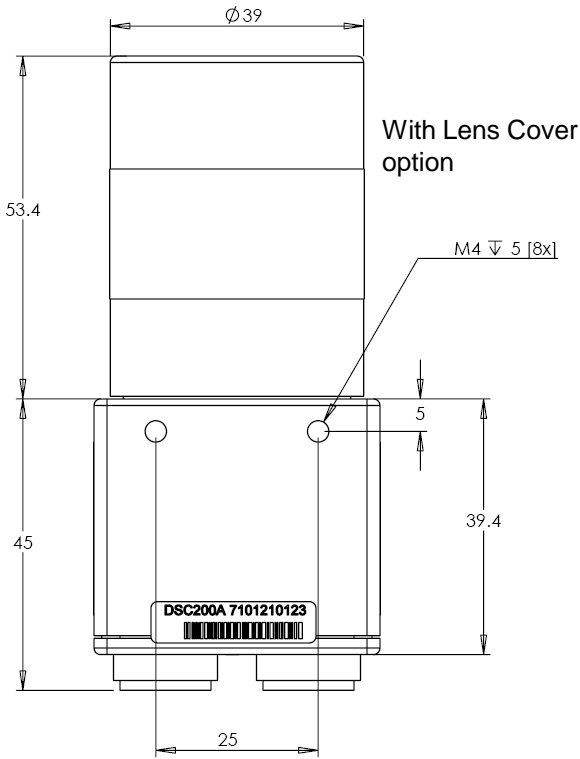

Bottom View

Note: All dimensions in mm

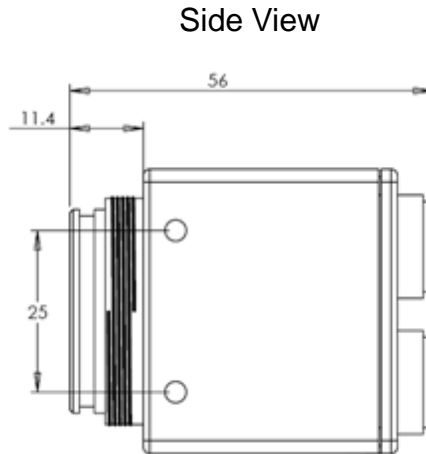

Side View

PL-100 Mechanical Dimensions

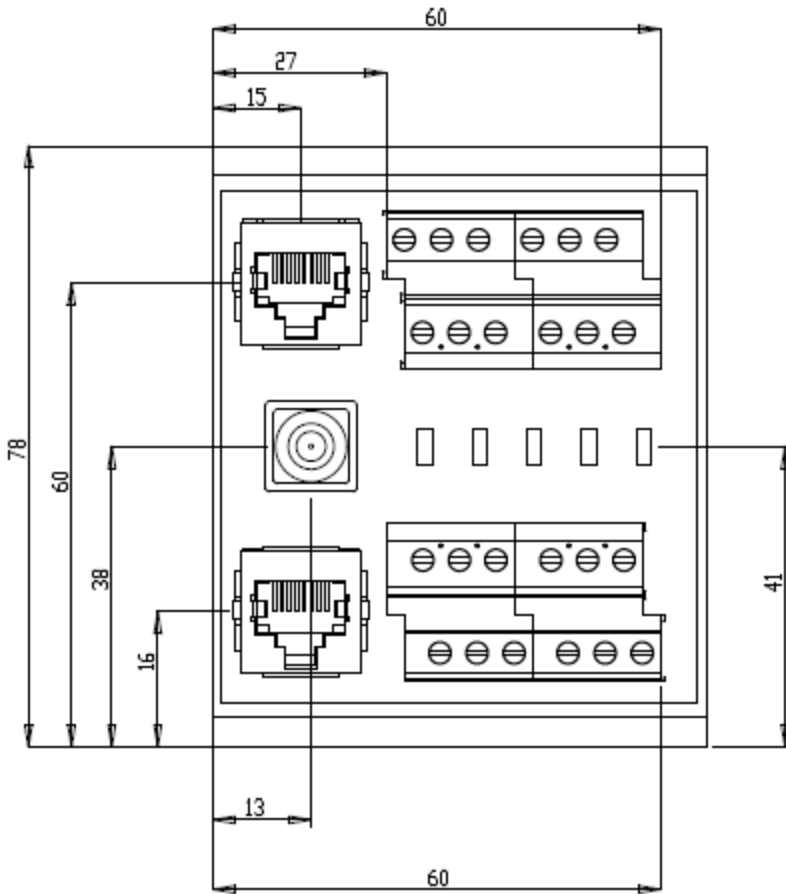

Top View

Note: All dimensions in mm

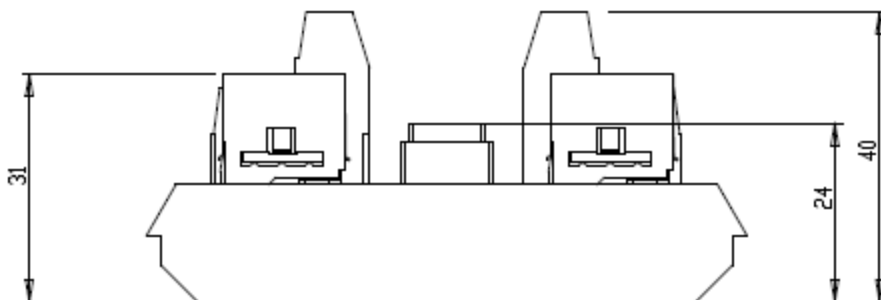

Side View

PL-200-IO Mechanical Dimensions

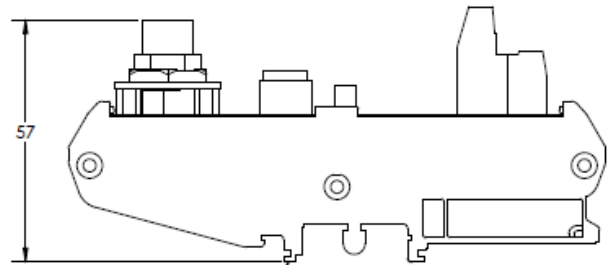
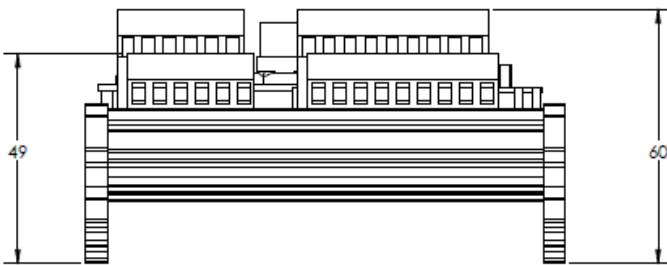
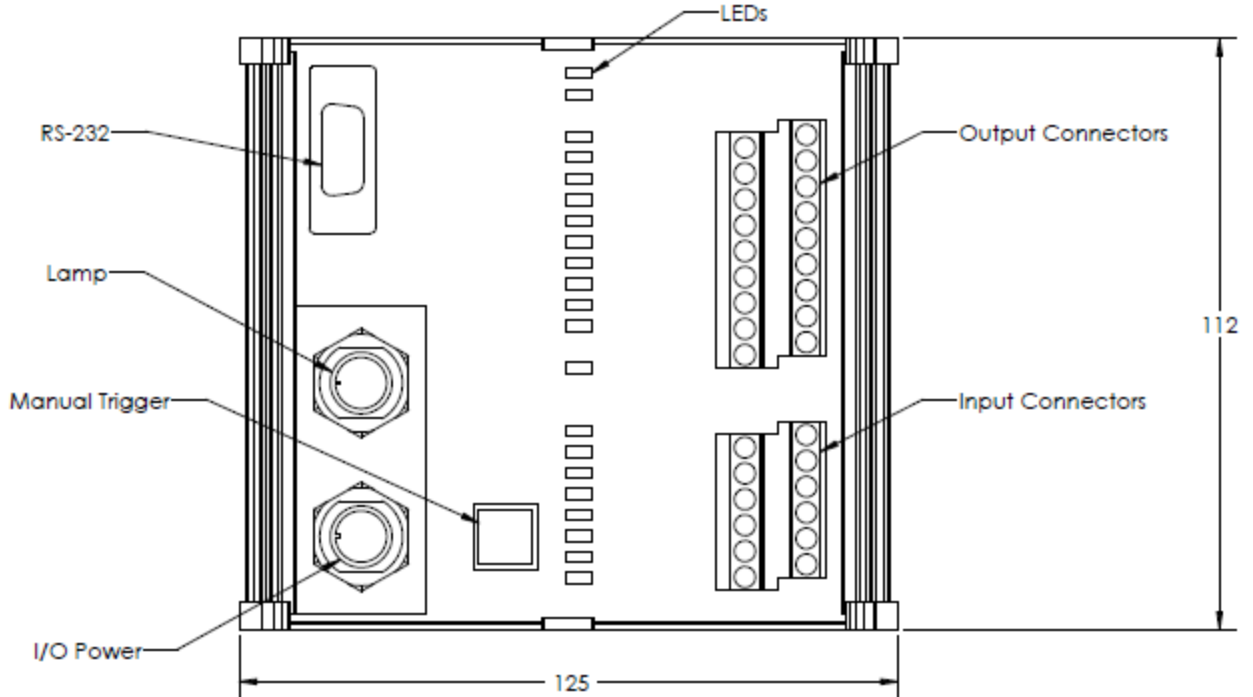

Note: All dimensions in mm

For dimensions of other versions of the PL-200, please refer to the PL-200 installation manual.