



945 East 11th Avenue Tampa, FL 33605

Phone: (813) 984-0125

Contact: Sales@pyramidimaging.com

https://pyramidimaging.com

REVISIONS				
ZONE	REV.	DESCRIPTION	DATE	APPROVED
	C	REVISED AND REDRAWN, KW	3/22/2012	
	D	REMOVED HEX NUTS AND ADJUSTED METRIC THREAD PITCH, KW	3/22/2012	
	E	REPLACED HEX NUTS, KW	4/3/2012	

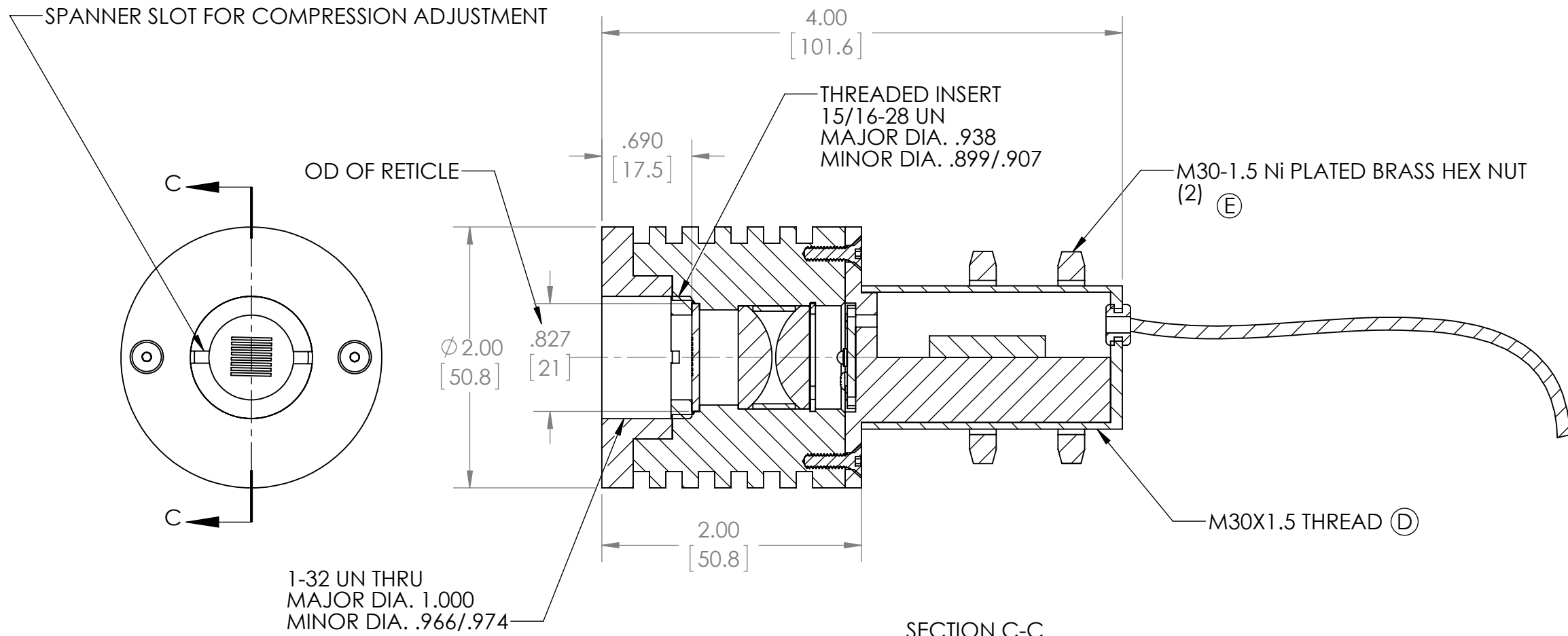

PROPRIETARY AND CONFIDENTIAL
THE INFORMATION CONTAINED IN THIS DRAWING IS THE SOLE PROPERTY OF <INSERT COMPANY NAME HERE>. ANY REPRODUCTION IN PART OR AS A WHOLE WITHOUT THE WRITTEN PERMISSION OF <INSERT COMPANY NAME HERE> IS PROHIBITED.

UNLESS OTHERWISE SPECIFIED:		NAME	DATE	METAPHASE TECHNOLOGIES, INC.	
DIMENSIONS ARE IN INCHES		DRAWN	KW	3/22/2012	TITLE: LIGHT ENGINE, LASERLINE
TOLERANCES:		CHECKED			
FRACTIONAL ± 1/64		ENG APPR.			
ANGULAR: MACH ± 1/2° BEND ± 2°		MFG APPR.			
TWO PLACE DECIMAL ± .01		Q.A.			SIZE DWG. NO. REV B LE250 E
THREE PLACE DECIMAL ± .005		COMMENTS:	MB-LPP		
INTERPRET GEOMETRIC TOLERANCING PER:				SCALE: 1:2	WEIGHT:
MATERIAL				SHEET 1 OF 1	
FINISH					
NEXT ASSY	USED ON				
APPLICATION				DO NOT SCALE DRAWING	