

8 7 6 5 4 3 2 1

| REVISIONS |      |                         |           |          |
|-----------|------|-------------------------|-----------|----------|
| ZONE      | REV. | DESCRIPTION             | DATE      | APPROVED |
|           | A    | REVISED AND REDRAWN, KW | 8/29/2011 |          |

ELECTRICAL CABLE  
(4) CONDUCTOR, 22 AWG  
10 FT LONG WITH FLYING LEADWIRE ENDS

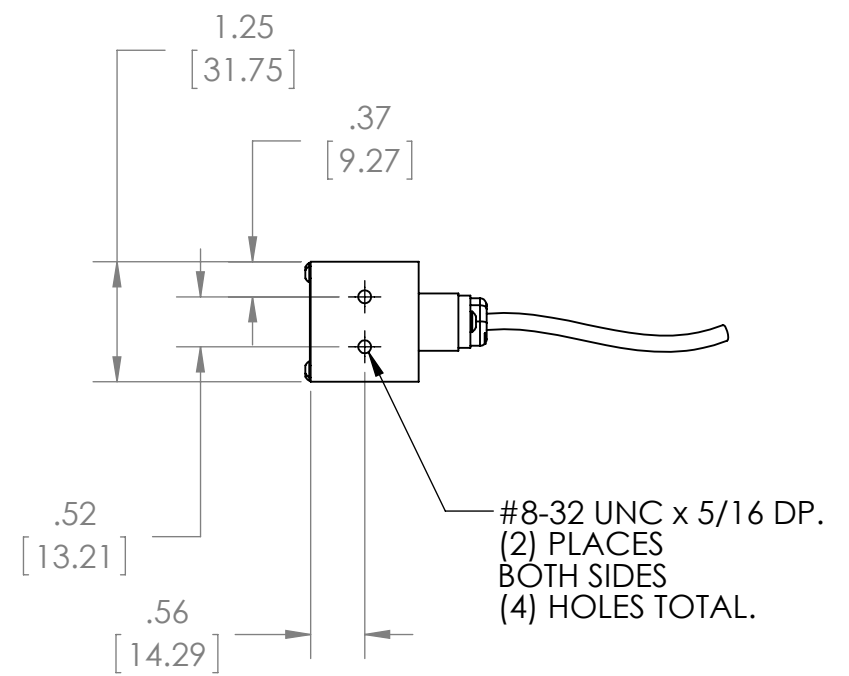
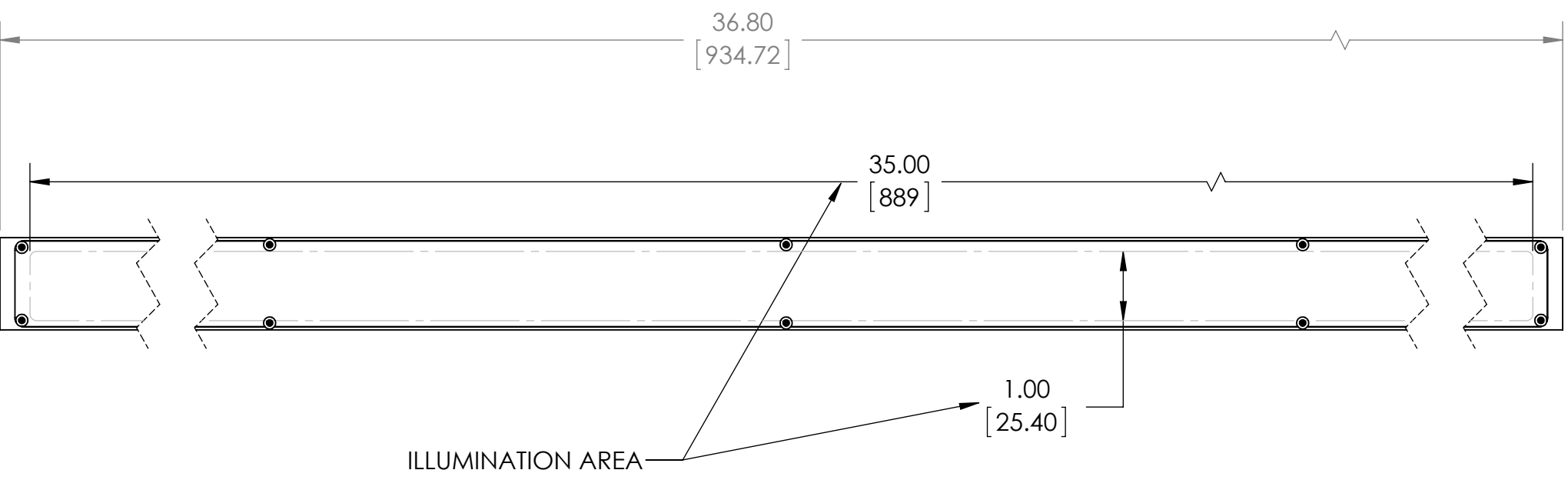
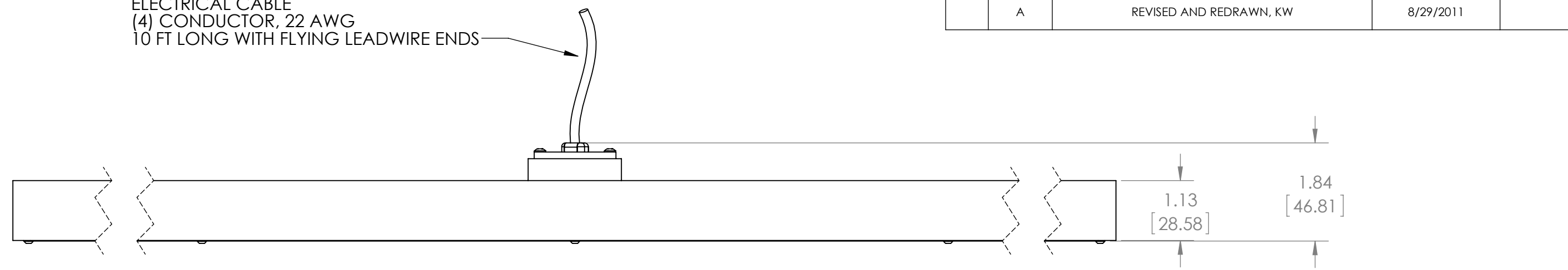

#8-32 UNC x 5/16 DP.  
(2) PLACES  
BOTH SIDES  
(4) HOLES TOTAL.

ILLUMINATION AREA



945 East 11<sup>th</sup> Avenue Tampa, FL 33605  
Phone: (813) 984-0125  
Contact: Sales@pyramidimaging.com  
<https://pyramidimaging.com>

**PROPRIETARY AND CONFIDENTIAL**  
THE INFORMATION CONTAINED IN THIS DRAWING IS THE SOLE PROPERTY OF <INSERT COMPANY NAME HERE>. ANY REPRODUCTION IN PART OR AS A WHOLE WITHOUT THE WRITTEN PERMISSION OF <INSERT COMPANY NAME HERE> IS PROHIBITED.

|             |         |                                      |  |           |      |                              |  |
|-------------|---------|--------------------------------------|--|-----------|------|------------------------------|--|
|             |         | UNLESS OTHERWISE SPECIFIED:          |  | NAME      | DATE | METAPHASE TECHNOLOGIES, INC. |  |
|             |         | DIMENSIONS ARE IN INCHES             |  | DRAWN     | KW   | 8-29-11                      |  |
|             |         | TOLERANCES:                          |  | CHECKED   |      | TITLE:                       |  |
|             |         | FRACTIONAL ±                         |  | ENG APPR. |      | FRONT LIGHT, LINEAR, 1 X 35  |  |
|             |         | ANGULAR: MACH ± BEND ±               |  | MFG APPR. |      | SIZE                         |  |
|             |         | TWO PLACE DECIMAL ±                  |  | Q.A.      |      | DWG. NO.                     |  |
|             |         | THREE PLACE DECIMAL ±                |  | COMMENTS: |      | LFL801                       |  |
|             |         | INTERPRET GEOMETRIC TOLERANCING PER: |  |           |      | REV                          |  |
|             |         | MATERIAL                             |  |           |      | A                            |  |
|             |         | FINISH                               |  |           |      | SCALE: 1:2                   |  |
| NEXT ASSY   | USED ON | DO NOT SCALE DRAWING                 |  |           |      | WEIGHT:                      |  |
| APPLICATION |         |                                      |  |           |      | SHEET 1 OF 1                 |  |

8 7 6 5 4 3 2 1