



945 East 11th Avenue Tampa, FL 33605

Phone: (813) 984-0125

Contact: Sales@pyramidimaging.com

https://pyramidimaging.com

REVISIONS				
ZONE	REV.	DESCRIPTION	DATE	APPROVED
	A	REVISED AND REDRAWN, KW	2/11/2011	
	B	REVISED DRAWING, KW	5/17/2012	

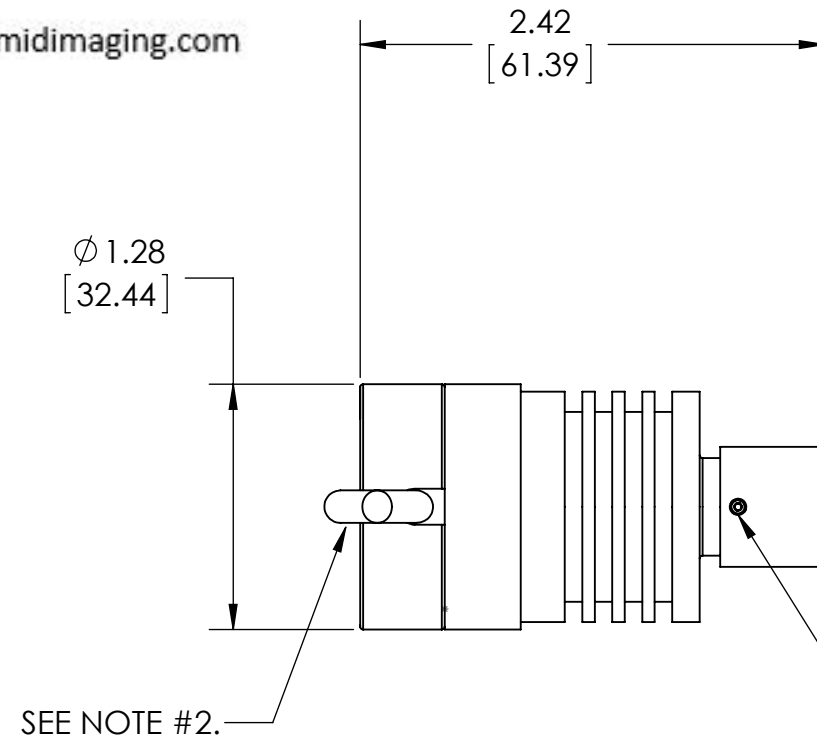
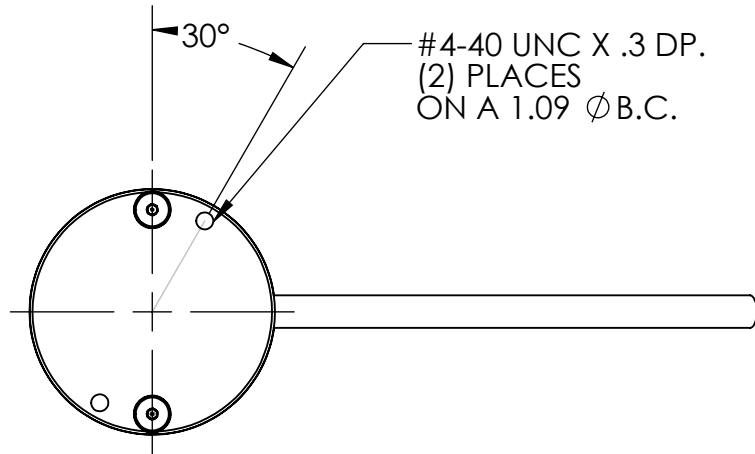

ADJUSTMENT SCREW
#2-56

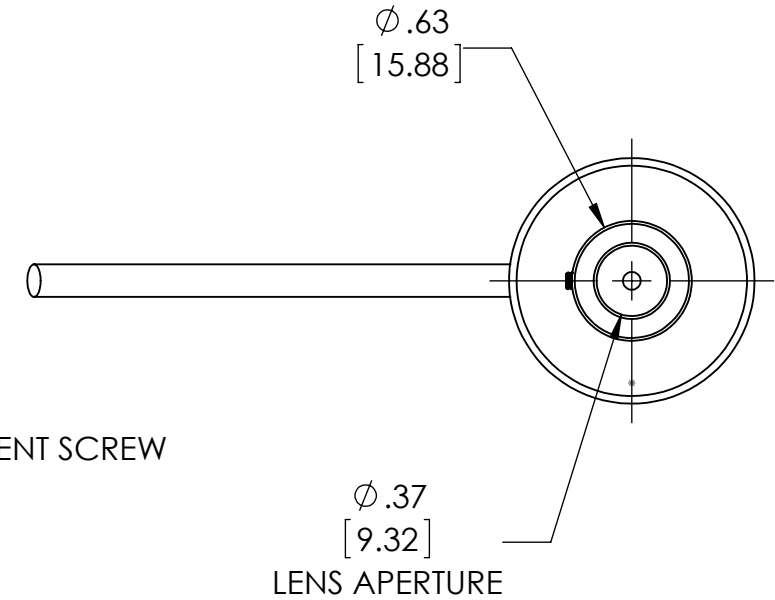

NOTES: UNLESS OTHERWISE SPECIFIED

1. FINISH: BLACK ANODIZED HOUSING.
2. 10 FT CABLE PROVIDED.
3. OPTIONAL HOLDING BRACKET- AB3-30.

PROPRIETARY AND CONFIDENTIAL
THE INFORMATION CONTAINED IN THIS DRAWING IS THE SOLE PROPERTY OF <INSERT COMPANY NAME HERE>. ANY REPRODUCTION IN PART OR AS A WHOLE WITHOUT THE WRITTEN PERMISSION OF <INSERT COMPANY NAME HERE> IS PROHIBITED.

		UNLESS OTHERWISE SPECIFIED:		NAME	DATE	METAPHASE TECHNOLOGIES, INC. TITLE: SPOTLIGHT ADJUSTABLE FOCUS			
		DIMENSIONS ARE IN INCHES TOLERANCES: FRACTIONAL \pm ANGULAR: MACH \pm BEND \pm TWO PLACE DECIMAL \pm THREE PLACE DECIMAL \pm		DRAWN	KW 2-11-11				
		INTERPRET GEOMETRIC TOLERANCING PER:		CHECKED					
		MATERIAL		ENG APPR.					
		FINISH		MFG APPR.					
NEXT ASSY	USED ON			Q.A.		SIZE	DWG. NO.	REV	
APPLICATION		DO NOT SCALE DRAWING		COMMENTS:		B	AFSL105 ^(A)	B	
						SCALE: 1:4		WEIGHT:	SHEET 1 OF 1