

REV	CHANGE RECORD AND DATE	CH
A	RELEASE 5/25/98	SSC

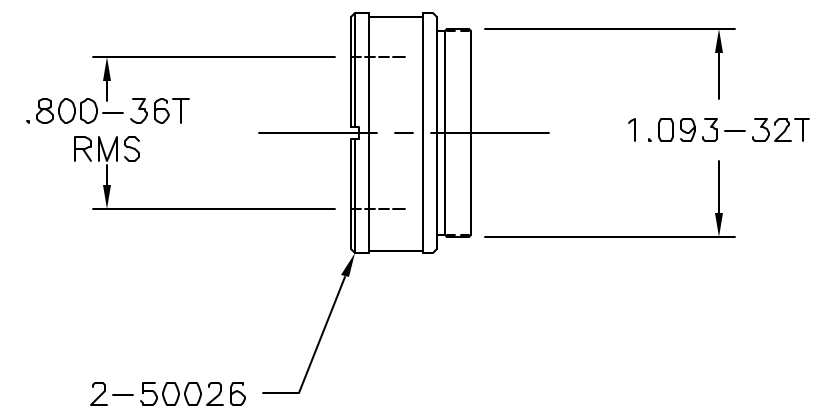
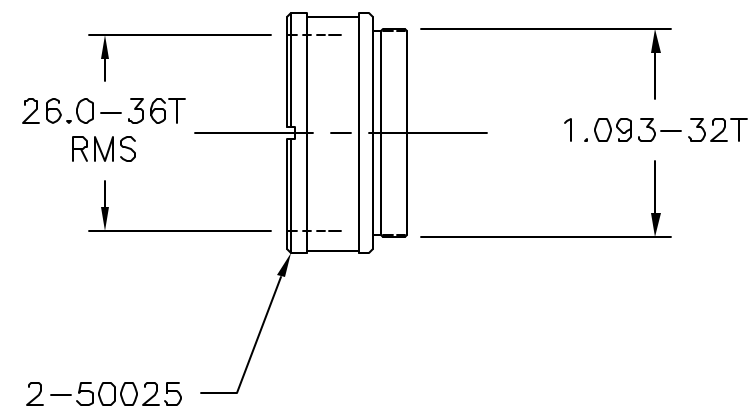
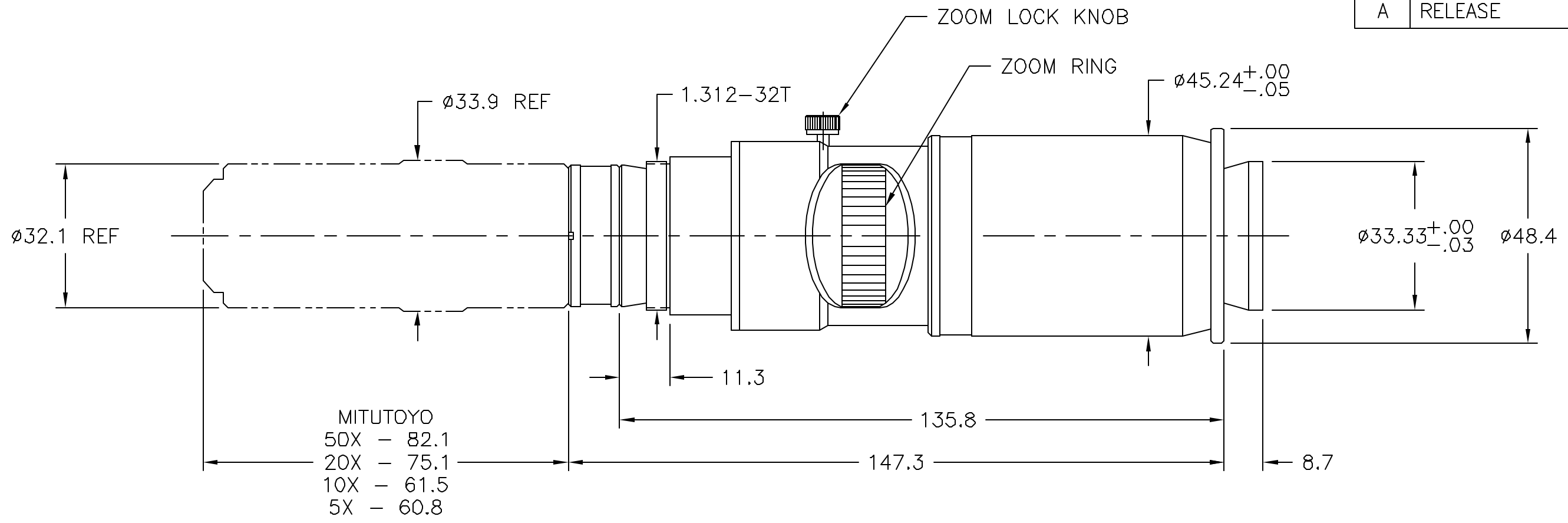

NEXT ASSY.

USED ON

1-50502 OL

MATERIAL	UNLESS OTHERWISE SPECIFIED DIMENSIONS ARE IN MM AND INCLUDE CHEMICALLY APPLIED OR PLATED FINISHES		P/N Suffix Definition -1 Conversion Coating -2 Painting -3 Marking -R Rework			
	TOLERANCES AS FOLLOWS DEC. .XX ±.10 DEC. .X ±.20 ANGLES ±30' CONCENTRICITY .08 TIR BREAK ALL SHARP EDGES .15 MIN. .25 MAX. MAX. SURF. ROUGHNESS $\sqrt{80}$				SCALE 1:1 DR. SSC CH. PB APP. - DATE DR. 9/25/98 DO NOT SCALE DRAWING	12X ULTRAZOOM LENS OUTLINE DWG.
FINISH	CHAMFER ALL THREADS 30° TO ROOT DIAM.			SIZE B	1-50502 OL SHT. 1 OF 1	