

---

VC-12MC-M/C 65

VC-25MC-M/C 30

VC-25MC-M/C 30 D

UP TO 25 MEGAPIXEL RESOLUTIONS, GLOBAL ELECTRONIC SHUTTER,  
HIGH-SPEED CMOS DIGITAL CAMERA



The VC-12MC-65, VC-25MC-30 and VC-25MC-30 D, the latest members of the CMOS-based VC series, are our new high resolution CMOS cameras with Camera Link interface. The VC-12MC uses the latest 12 megapixel CMOS sensor (CMV12000) technology from CMOSIS, and performs as fast as 64 fps with high quality image. The VC-25MC-30 is based on ON Semiconductor VITA-25K CMOS sensor delivering high quality 25 megapixel images at 30 fps. The VC-25MC-30 D uses the latest 25 megapixel CMOS image sensor (PYTHON-25K) technology from On Semiconductor, and delivers high quality images at 30 fps. With their high resolution and fast speed, these cameras are ideal for applications such as PCB inspection, AOI machines, 3D inspection and many others.



# VC-12MC-65 / VC-25MC-30 / VC-25MC-30 D

UP TO 25 MEGAPIXEL RESOLUTIONS, GLOBAL ELECTRONIC SHUTTER, HIGH-SPEED CMOS DIGITAL CAMERA

## Main Features

- \* Resolutions from 12MP up to 25MP
- \* High-Speed Progressive Scan CMOS Image Sensor
- \* Global Shutter CMOS Technology
- \* Full Camera Link Interface with 8 bit or 10 bit Data Output
- \* Excellent Noise Reduction and Heat Treatment
- \* Field Upgradable Firmware
- \* Pixel Defect Correction

## Applications

- \* PCB Inspection
- \* Semiconductor Inspection
- \* 3D Inspection
- \* Scientific Research Imaging

## Specifications

Model	VC-12MC-M/C 65	VC-25MC-M/C 30	VC-25MC-M/C 30 D
Resolution (H × V)	4096 × 3072	5120 × 5120	5120 × 5120
Sensor	CMOSIS CMV 12000	On Semiconductor VITA-25K	On Semiconductor PYTHON-25K
Sensor Size	22.5 mm × 16.9 mm (Diagonal: 28.1 mm)	23.04 mm × 23.04 mm (Optical Format: 35 mm)	23.04 mm × 23.04 mm (Diagonal: 32.6 mm)
Sensor Type	High Speed CMOS Image Sensor		
Pixel Size	5.5 μm × 5.5 μm	4.5 μm × 4.5 μm	
Interface	Camera Link		
Max. Frame Rate	2 Tap: 13.0 fps	2 Tap: N/A	2 Tap: N/A
	4 Tap: 26.0 fps	4 Tap: N/A	4 Tap: N/A
	8 Tap: 51.7 fps	8 Tap: 25.0 fps	8 Tap: 25.3 fps
	10 Tap: 64.3 fps	10 Tap: 30.9 fps	10 Tap: 30.1 fps
Transfer Time	2 Tap: 76.9 ms	2 Tap: N/A	2 Tap: N/A
	4 Tap: 38.5 ms	4 Tap: N/A	4 Tap: N/A
	8 Tap: 19.4 ms	8 Tap: 40.00 ms	8 Tap: 39.52 ms
	10 Tap: 15.6 ms	10 Tap: 32.36 ms	10 Tap: 33.22 ms
Pixel Data Format	8 bit (2/4/8/10 Tap) 10 bit (2/4/8 Tap)		
Electronic Shutter	Global Shutter		
Data Output Pixel Clock Speed	85 MHz		
Trigger Mode	Free-Run, Trigger Programmable Exposure Time and Trigger Polarity		
Dynamic Range	60 dB	54 dB	59 dB
Dimension / Weight	68 mm × 68 mm × 80 mm, 432 g (F-mount)		
Temperature	Operating: 0°C ~ 40°C, Storage: -40°C ~ 70°C		
Lens Mount	F-mount, Custom mount available upon request		
Power	10 ~ 14 V DC, Typ. 5 W	10 ~ 14 V DC, Typ. 6 W	10 ~ 14 V DC, Typ. 7 W
Compliance	CE, FCC, KC		
Configuration Software	Configurator		

# VC-12MC-65 / VC-25MC-30 / VC-25MC-30 D

UP TO 25 MEGAPIXEL RESOLUTIONS, GLOBAL ELECTRONIC SHUTTER, HIGH-SPEED CMOS DIGITAL CAMERA

## Quantum Efficiency Curves

VC-12MC-65

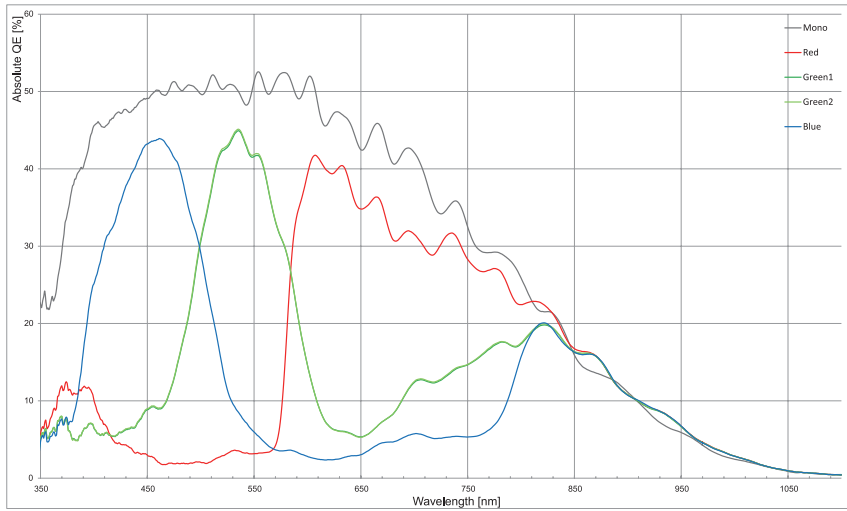

VC-25MC-30

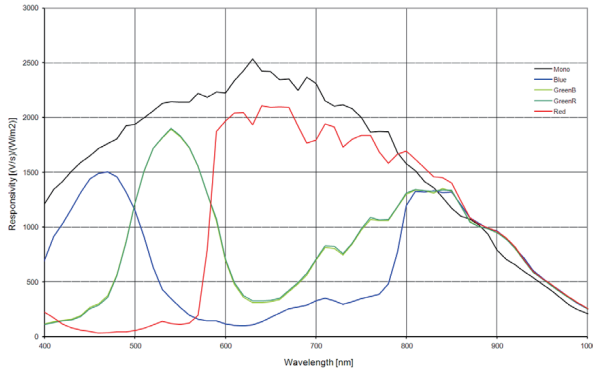

VC-25MC-30 D

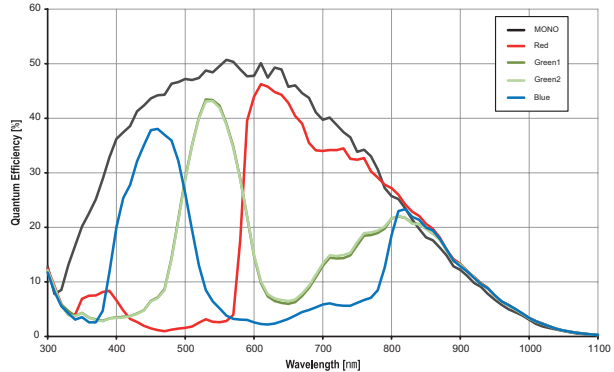

## Ordering Scheme

<p>Series</p> <p>VC Series</p>		<p>Sensor Options</p> <p>C - Onsemi CMOS (Vita)</p> <p>D - Onsemi CMOS (Python)</p> <p>F - AMS (CMV)</p>	
<p>Sensor Resolution</p> <p>12M - 12 Megapixels</p> <p>25M - 25 Megapixels</p>		<p>Frame Rate</p> <p>30 - 30 fps</p> <p>65 - 64 fps</p>	
<p>Interface</p> <p>C - Camera Link</p>		<p>Mono / Color</p> <p>M - Monochrome</p> <p>C - Color</p>	

## Connector Specification

Power



1 2 3: +12V DC, 4 5 6: GND  
(HR10A-7R-6PB)

Control

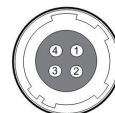

1: Trigger IN+, 2: Trigger IN-  
3: DC Ground, 4: Strobe OUT+  
(HR10A-7R-4S)

Connectors on camera body

# VC-12MC-65 / VC-25MC-30 / VC-25MC-30 D

UP TO 25 MEGAPIXEL RESOLUTIONS, GLOBAL ELECTRONIC SHUTTER, HIGH-SPEED CMOS DIGITAL CAMERA

## Mechanical Dimensions

Unit: mm

F-mount for VC-12MC-65, VC-25MC-30 and VC-25MC-30 D

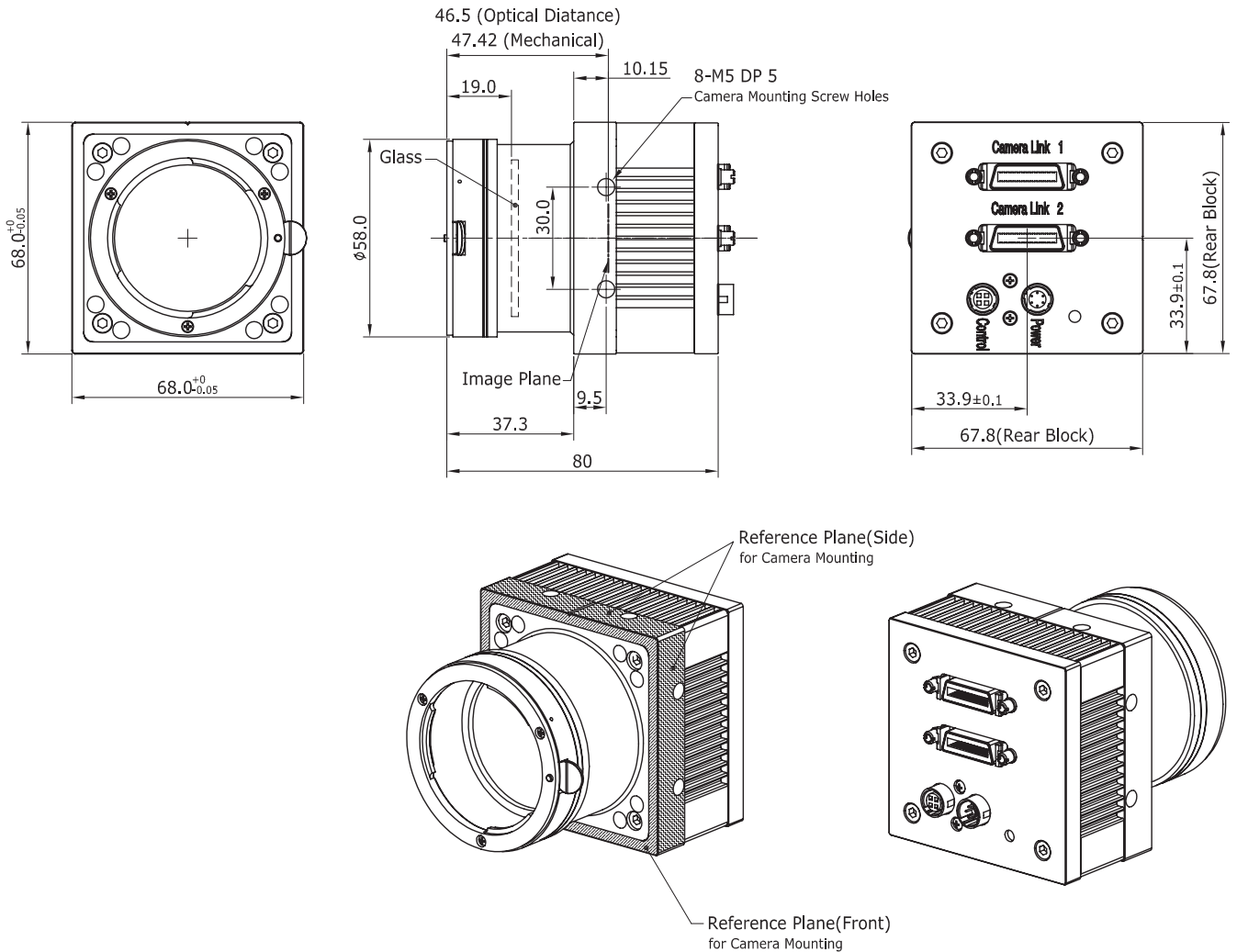

For more information please contact local distributor or visit our website at <http://www.pyramidimaging.com>.

RA14-137-036

