

L10 Series

apg

Allison Park Group, Inc.

The L10 Series enclosure is a 316 stainless steel housing for upright cameras, lasers, or sensors. Designed to work in highly corrosive environments, it also is designed to work in food applications, with care taken to reduce pockets where water might sit.

Product Features

- All 316 stainless construction
- Designed for highly corrosive environments
- Constructed of food safe materials for FDA washdown/ food applications
- IP69K option
- Split cable gland designed for premade cables

Construction

- 316 stainless steel body and fasteners
- Tumbled polish finish

Environment

- NEMA 6/IP68



Camera and Lens Size Viewing Window

Camera Specific Models	Camera Mounting	Viewport	Viewing Area	Cable Entry
Model L10-AA Length: 278mm Net weight: 2.9 kg (6.4 lbs), Gross weight: 3.3 kg (7.2 lbs)	PPT A Series/Matrox GT/NI Smart Camera	Abrasion resistant optical grade acrylic	69mm Dia.	PG36 Split cable gland
Model L10-AB Length: 278mm Net weight: 2.9 kg (6.4 lbs), Gross weight: 3.3 kg (7.2 lbs)	PPT A Series/Matrox GT/NI Smart Camera	Abrasion resistant optical grade acrylic	69mm Dia.	PG36 Split cable gland
Model L10-AC Length: 278mm Net weight: 2.9 kg (6.4 lbs), Gross weight: 3.3 kg (7.2 lbs)	PPT A Series/Matrox GT/NI Smart Camera	Abrasion resistant optical grade acrylic	69mm Dia.	PG36 Split cable gland
Model L10-BC Length: 278mm	PPT A Series/Matrox GT/NI Smart Camera	Abrasion resistant optical grade acrylic	69mm Dia.	PG36 Split cable gland

L10 Series

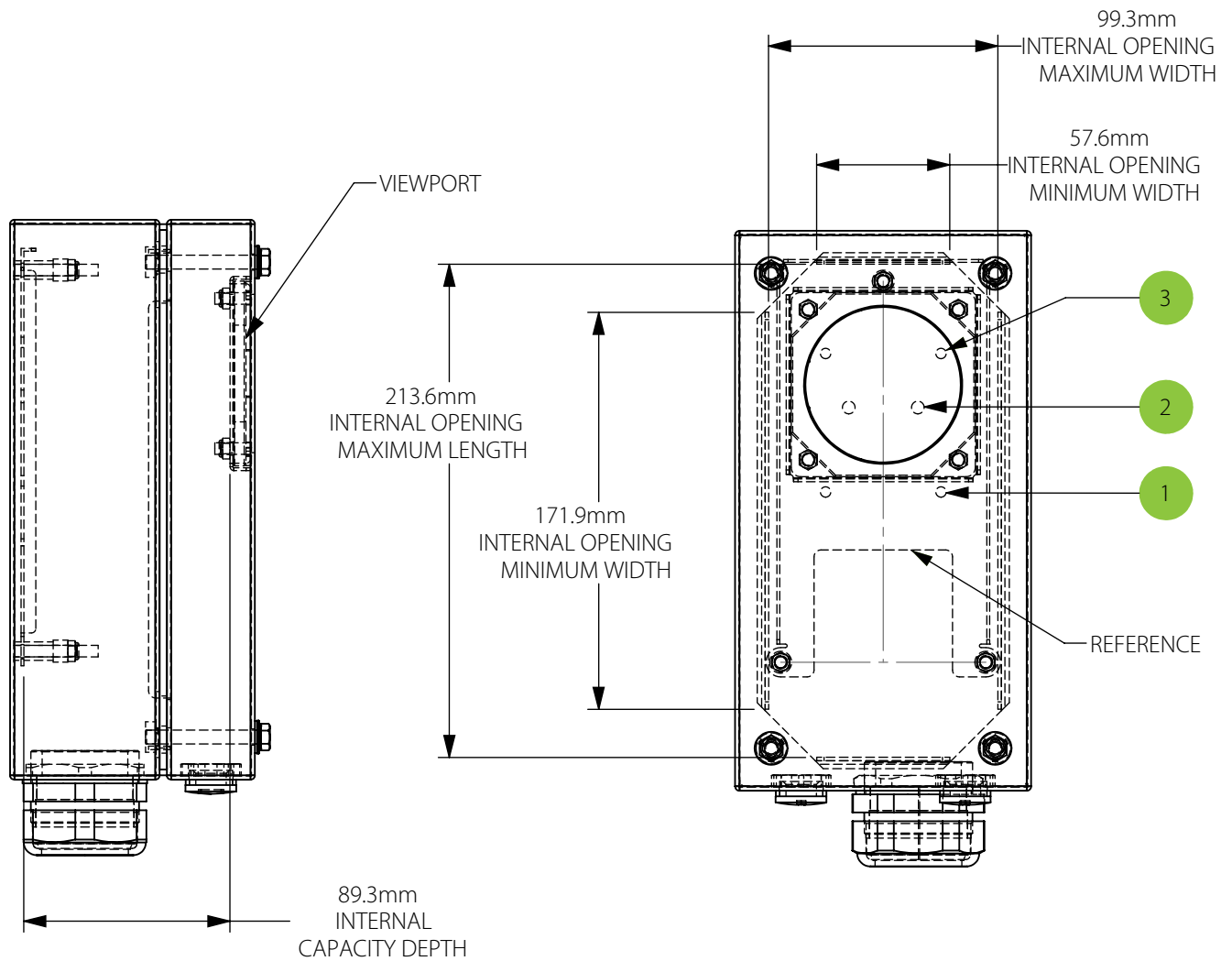

Item Number	Fastener Size, metric	Hole Spacing Across Width, mm	Distance from Reference, mm
1	M4	50	25.1
2	M5	29.9	61.7
3	M4	50	85.1



945 East 11th Avenue
 Tampa, FL 33605
 Phone: (813) 984-0125
 Contact: Sales@pyramidimaging.com
<https://pyramidimaging.com>