

Pyramid Imaging, Inc.  
 945 East 11th Avenue  
 Tampa, FL 33609  
 sales@pyramidimaging.com  
 www.pyramidimaging.com  
 813-786-3785

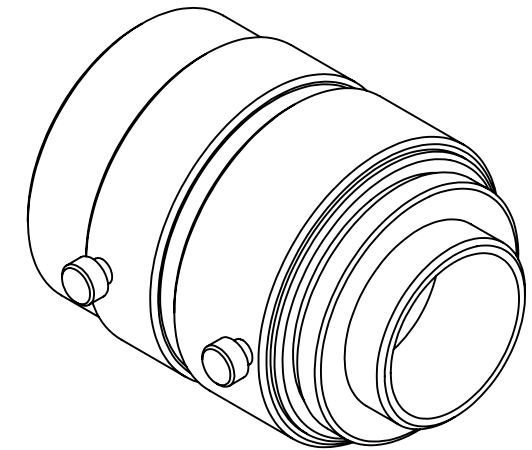

### OUTLINE

Lens Specifications - NMV - 12			
Specifications	Value	1/2"	1/3"
Focal Length	f = 12mm		
Maximum diameter (Ratio)	F = 1.4:1 ~ 16 ~ Close		
Element	6gp. 6 Element		
Picture Size	6.6 x 8.8mm	4.8 x 6.4mm	3.6 x 4.8 mm
Angle - Vertical	31.7 deg.	23.0 deg.	17.2 deg.
Horizontal	42.5 deg.	30.7 deg.	23.0deg.
Diagonal	53.7 deg.	38.5 deg	28.8deg.
Distortion	-10.7%	-5.0%	-2.7%
Shooting Range - Vertical	173mm	123.8mm	92.2mm
At Minimum - Horizontal	237mm	167.2mm	123.8mm
Focus Distance - Diagonal	307mm	212.8mm	156.2mm
Minimum Focus Distance	0.1m		
Flange Back	17.526mm in air		
Back Focus	11.12mm in air		
Filter Screw Size	M27 X 0.5		
Effective Diameter - Front	12.3mm dia.		
- Rear	11.7mm dia.		
Mount	C-Mount		
Exit Pupil	-38.9mm dia.		
Temperature Range	- 10 ~ + 45 deg. C		
Strong Temperature Range	- 40 ~ + 60 deg. C		
Resolution - Center	100 Lp/mm		
- Corner	40 Lp/mm		

UNLESS OTHERWISE SPECIFIED DIMENSIONS ARE IN INCHES AND INCLUDE CHEMICALLY APPLIED OR PLATED FINISHES	THE CONTENTS OF THIS DOCUMENT ARE PROPRIETARY TO NAVITAR, ITS USE IS AUTHORIZED ONLY FOR RESPONDING TO REQUEST FOR QUOTATION OR PERFORMANCE OF WORK FOR NAVITAR			
	SCALE: 1.5:1			WEIGHT: See Table
DR: BE	CH:			
PROJECT #: E2338	DATE DR: 7/13/2007			
DO NOT SCALE DRAWING		SIZE B	<b>NMV - 12</b> SHEET 1 OF 1	REV A

LENS, 12.0mm FL, , 2/3", f/1.4