

REVISIONS			
REV.	DESCRIPTION	DATE	APPROVED
A	INITIAL DESIGN BUILD	1/1/2014	
B	SECOND GENERATION RELEASE	3/27/2014	
C	ADDED OPTIONAL DUST COVER	5/2/2018	

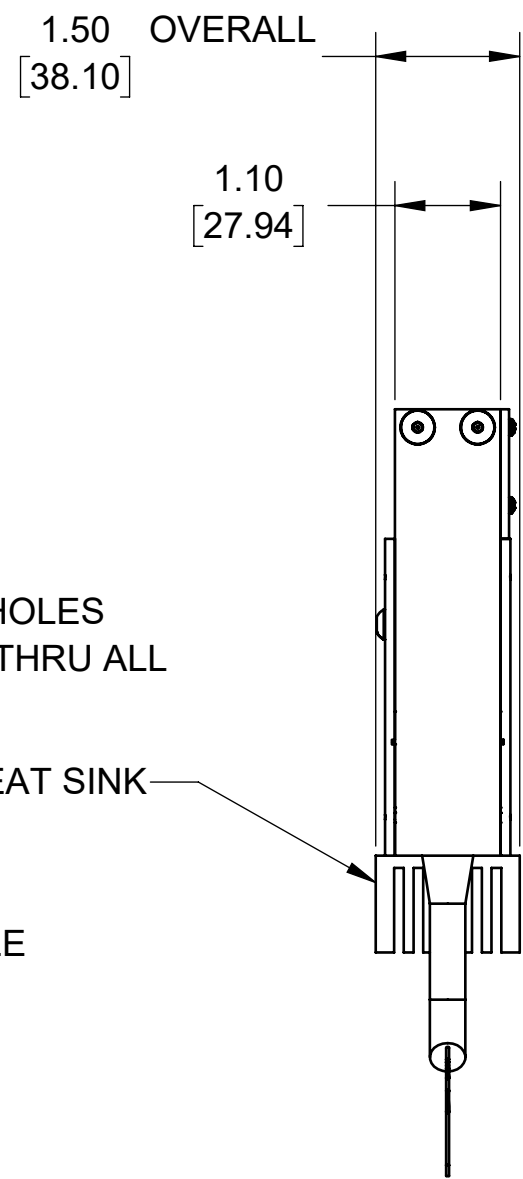

945 East 11<sup>th</sup> Avenue  
 Tampa, FL 33605  
 Phone: (813) 984-0125  
 Contact: [Sales@pyramidimaging.com](mailto:Sales@pyramidimaging.com)  
<https://pyramidimaging.com>

Metaphase Technologies, Inc. 211 Sinclair Road, Suite 100, Bristol, PA. 19007 215-639-8699 Fax 215-639-0977



SEE SHEET 2 FOR EXPLODED VIEW AND BOM.

<b>QUANTITY:</b>	Per order	TOLERANCE/FINISH UNLESS OTHERWISE SPECIFIED			
<b>MATERIAL:</b>	Per BOM	INCHES [MM]			
<b>FINISH:</b>	As supplied	X	.X	.XX	.XXX
<b>TREATMENT:</b>	N/A	[±.76]	±.030 [±.25]	±.010 [±.13]	±.005
					125√RMS [RA3.2um]
					ANGLES ±1°

THIS DOCUMENT IS THE PROPERTY OF METAPHASE TECHNOLOGIES, INC. WHOM MAY LOAN IT, SUBJECT TO RETURN UPON DEMAND. IT INCLUDES CONFIDENTIAL & PROPRIETARY INFORMATION WHICH MAY NOT BE DISCLOSED TO ANY THIRD PARTY, AND/ OR USED FOR ANY PURPOSE CONTRARY TO IT'S INTENDED USE, WITHOUT THE EXPRESSED PRIOR WRITTEN CONSENT OF METAPHASE TECHNOLOGIES, INC.

TITLE	Assy, 10" Diff Axial Line Lt		
USED ON	Per customer		
SIZE	DRAWING NUMBER	REV	
B	DALL-306-1	C	
SCALE 1:2	SHEET 1 OF 2		

Approval Signature

/ /  
Date

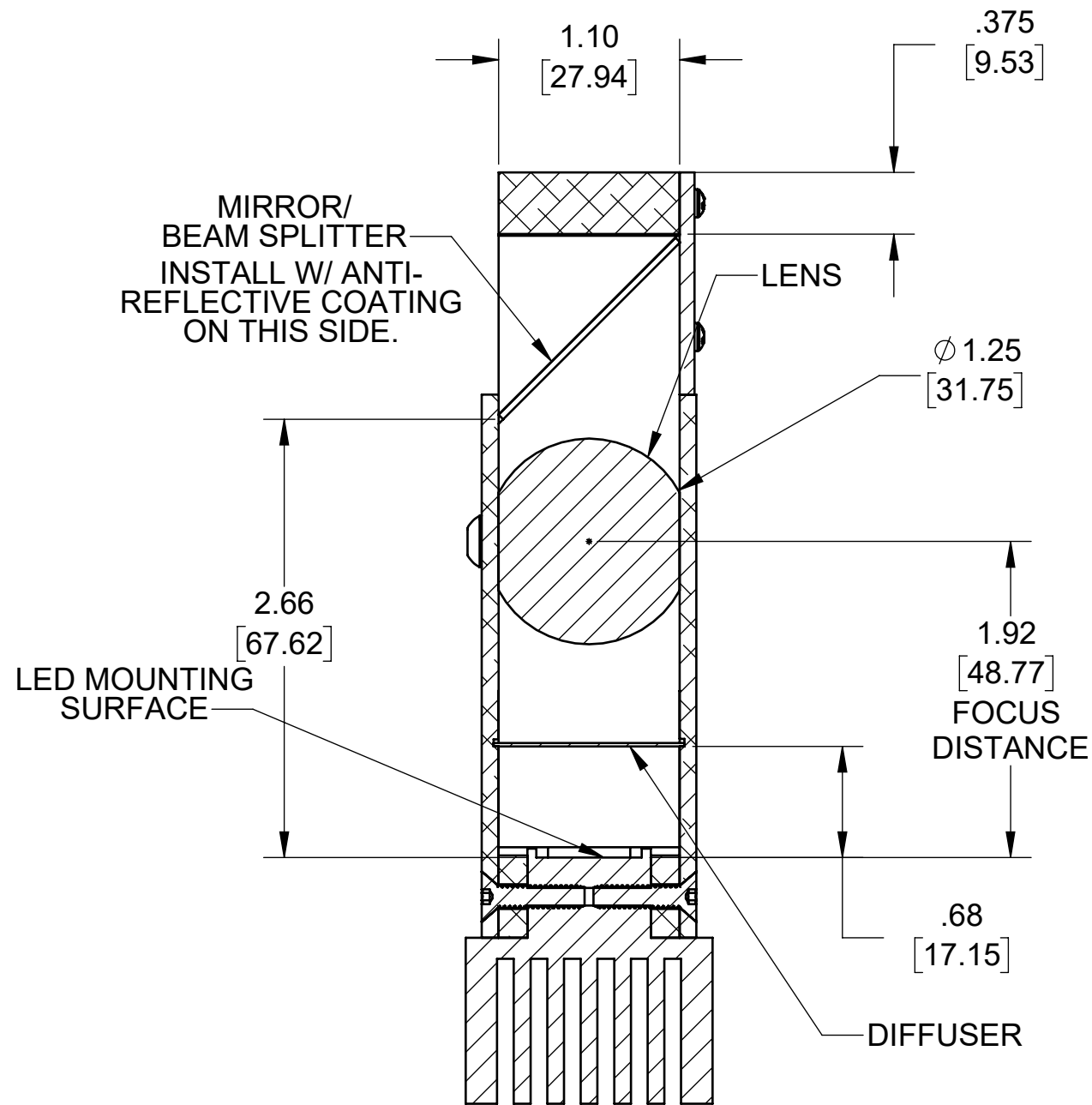

SECTION A-A  
SCALE 1 : 1

Metaphase Technologies, Inc. 211 Sinclair Road, Suite 100,  
Bristol, PA. 19007 215-639-8699 Fax 215-639-0977



TOLERANCE/FINISH UNLESS OTHERWISE SPECIFIED				
	INCHES[MM]			125√RMS [RA3.2um]
X	.X	.XX	.XXX	
[±.76]	±.030 [±.25]	±.010 [±.13]	±.005	ANGLES ±1°
FLAT PATTERNS USE 0.5 K FACTOR FOR DESIGN REFERENCE ONLY. ACTUAL VALUE MAY VARY, USE TEST PART AS REQ'D TO VERIFY ACCURACY				

THIS DOCUMENT IS THE PROPERTY OF **METAPHASE TECHNOLOGIES, INC.** WHOM MAY LOAN IT, SUBJECT TO RETURN UPON DEMAND. IT INCLUDES CONFIDENTIAL & PROPRIETARY INFORMATION WHICH MAY NOT BE DISCLOSED TO ANY THIRD PARTY, AND/ OR USED FOR ANY PURPOSE CONTRARY TO IT'S INTENDED USE, WITHOUT THE EXPRESSED PRIOR WRITTEN CONSENT OF **METAPHASE TECHNOLOGIES, INC.**

TITLE  
Assy, 10" Diff Axial Line Lt

USED ON  
Per customer

SIZE <b>B</b>	DRAWING NUMBER <b>DALL-306-1</b>	REV <b>C</b>
SCALE 1:2	SHEET 2 OF 2	