

The Componon-S 5.6/100 (Version -0015) is a 100 mm focal length enlarging lens with 108 mm image circle for large format sensors and short working distance. This lens can also be used in reverse position. The modular system with wide-ranging accessories such as helical focus barrel (Unifoc 58 and 76), extension tubes, and adapters for various cameras, can be used for all kind of sophisticated applications from web inspection to laser triangulation. This, the fast F/# of 5.6 and low chromatic aberration, as well as extremely low distortion all combined make these lens unique. Vibration insensitivity for stable imaging performance even when the lens used in harsh industrial environmental, as common in OLED inspection and quality control systems. The Unifoc Series offers more enlarging lenses with 28 mm, 35 mm, 40 mm, 45 mm, 50 mm, 60 mm, 80 mm, 90 mm, 135 mm, 150 mm focal length and a macro lens series and a line scan lens series both for Unifoc 7 and 12 helicoid focus barrels.

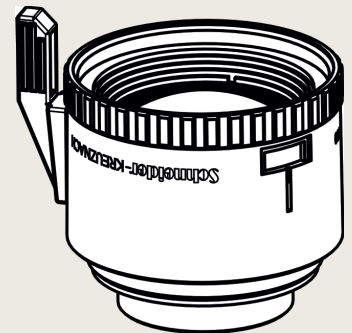

Componon-S 5.6/100

Key features

- Large format
- Short working distance
- Modular: Unifoc 58 and 76 focus helical barrels, extension tubes, various camera adapters
- Possibility to be used in retro position
- Vibration insensitivity for stable imaging performance

Applications

- Solar inspection
- OLED inspection
- Line scan applications
- Laser triangulation
- Quality control

Name	Componon-S 5.6/100
Type	-0015
Focal Length [mm]	100
Magnification	-0.5
Image circle [mm]	108
Resolution [μ m]	6.45
F/# range	5.6 ... 32
NA	0.09
Interface	Leica-Mount
Working distance [mm]	295
AoV [°]	56
Focus control	manual
Transmission [nm]	400 - 1000
Filter thread [mm]	M37 x 0.75
Dimensions L x D [mm]	41.5 x 46.0

Name	Componon-S 5.6/100
Weight [g]	90
Storage temperature [°C]	-25 ... +70
f'_{eff} [mm]	102.34
S_F [mm]	-81.84
S'_F [mm]	84.88
HH' [mm]	-2.38
β'_p	0.988
S_{EP} [mm]	21.76
S'_{AP} [mm]	-16.21
Σd [mm]	35.58
ID	14022

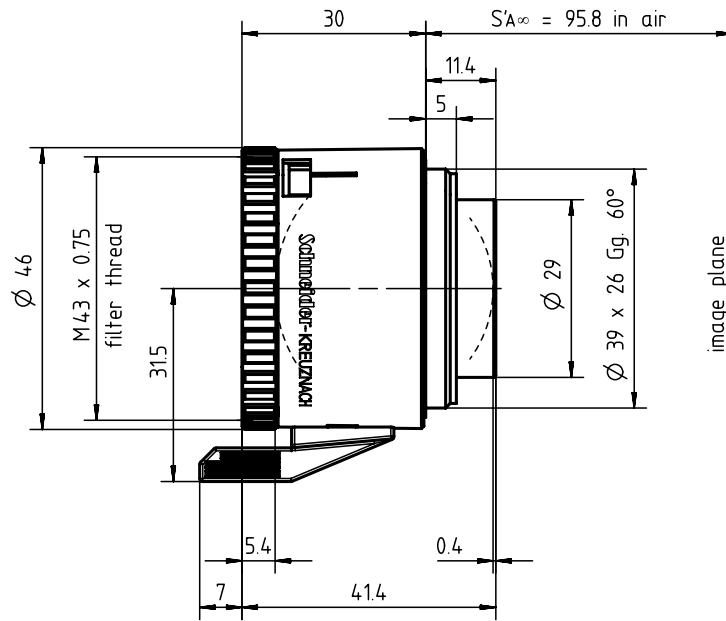

Distortion vs. Image Height

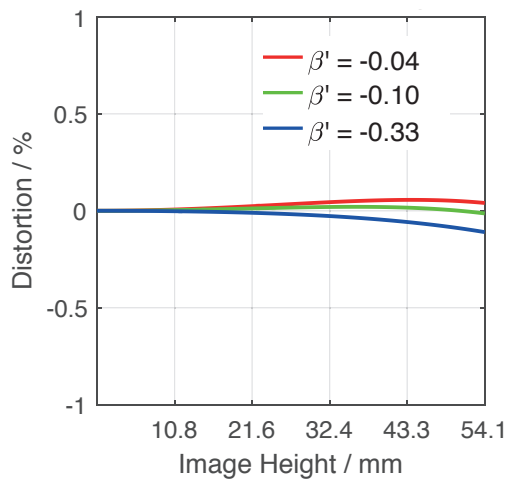

Transmittance vs. Wavelength

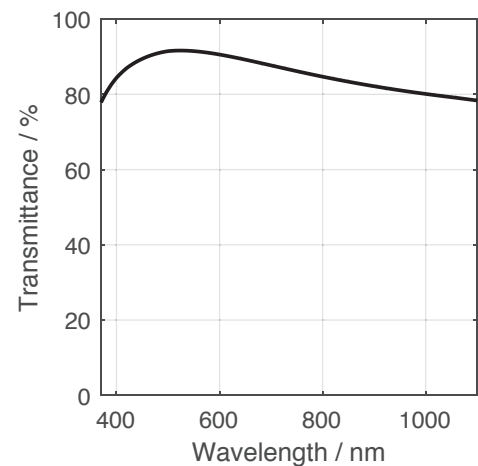

Relative Illumination vs. Image Height

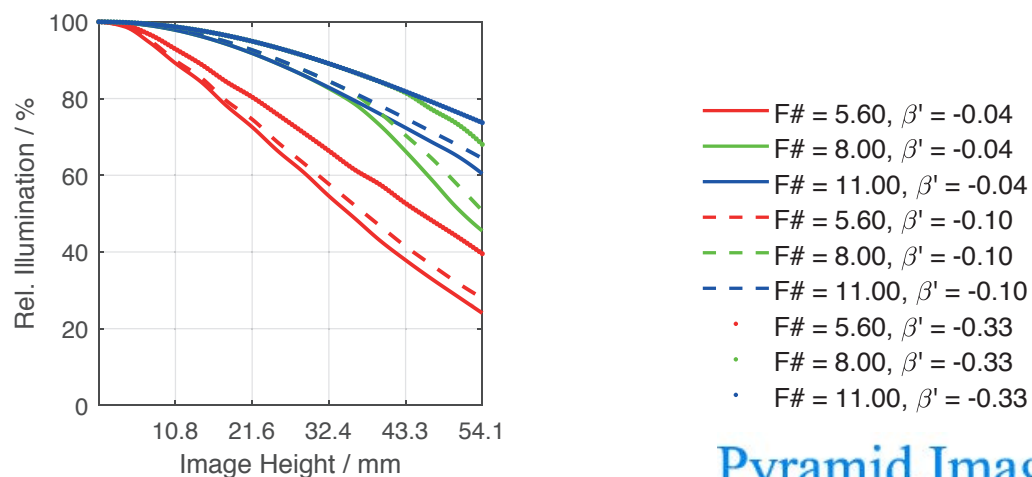

Spectrum Name	VIS					
Wavelengths [nm]	425	475	525	575	625	675
Weights	8	16	23	22	19	13

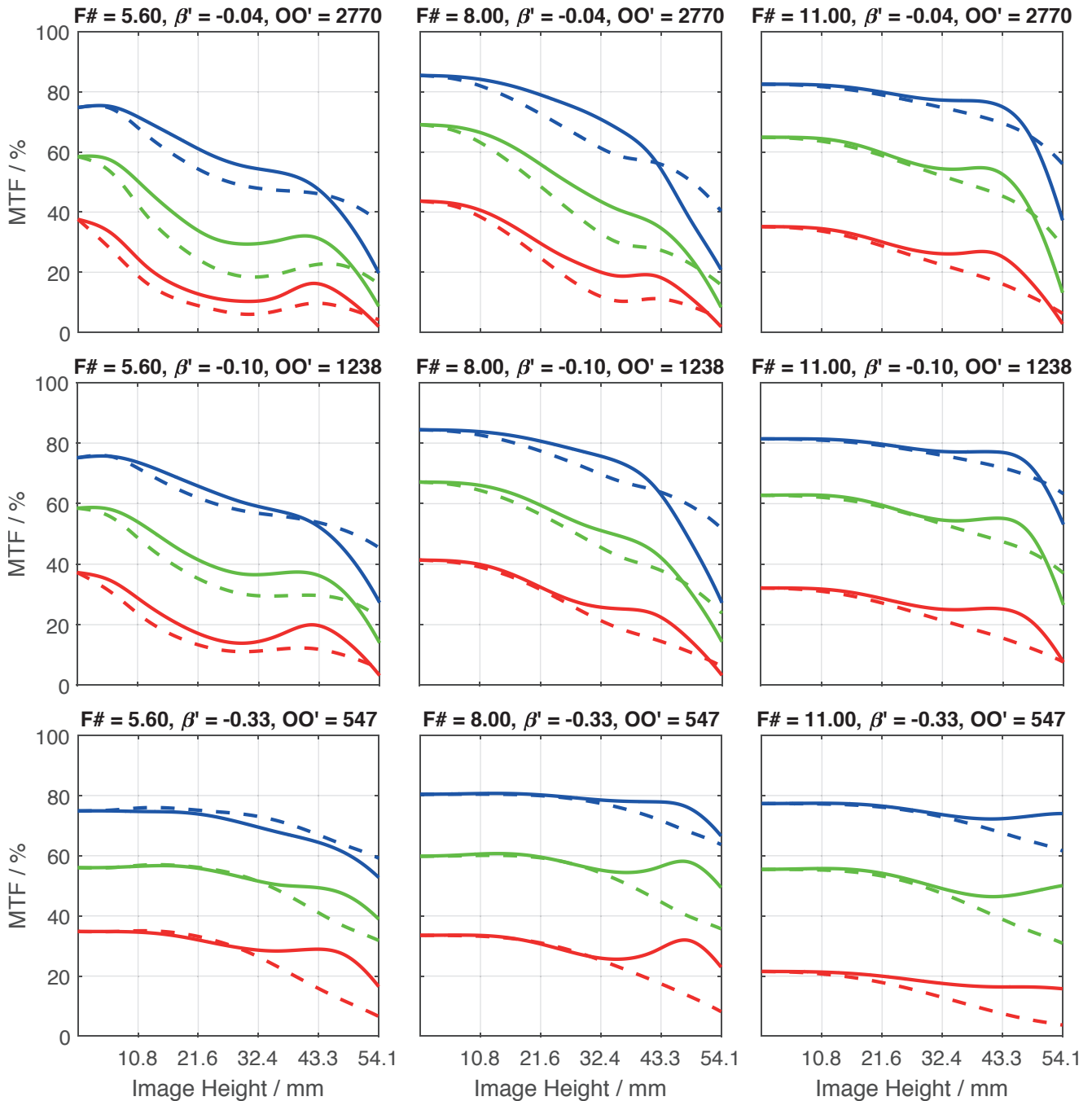

- 20.0 lp/mm, tangential - - - 40.0 lp/mm, tangential - - - 80.0 lp/mm, tangential
- 20.0 lp/mm, radial — 40.0 lp/mm, radial — 80.0 lp/mm, radial

Accessories	Mount	Length	ID
Macro	UNIFOC 58 Leica / T2	-	39549
	UNIFOC 76 Leica / M58 x 0.75	-	13048
Ext. Tube	T2 / T2	25 mm	41643
	M58 x 0.75	10 mm	13051
	M58 x 0.75	25 mm	13050
	M72 x 0.75	5 mm	1072420
	M72 x 0.75	10 mm	1072421
	M72 x 0.75	25 mm	26406
	M72 x 0.75	50 mm	1054733
	M95 x 1.0	25 mm	1062892
	M95 x 1.0	50 mm	1062893
	M95 x 1.0	100 mm	1062894
	Adapter	T2 / C-Mount	-
T2 / Nikon		-	21591
T2 / M42 x 1.0		-	21592
M50 x 0.75 for CPN-S 135/150		-	17231
M72 / 4 x M3 (M4)		-	1071925
M58 / M72 x 0.75		-	13052
M58 / M95 x 1		-	1062891

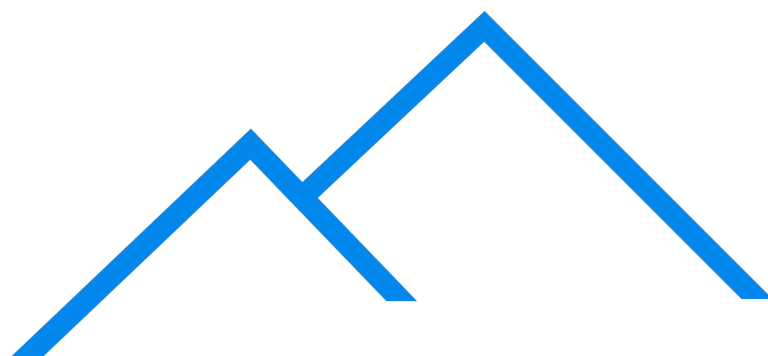

Pyramid Imaging

Get more information

Contact our local offices



Headquarter Germany

Jos. Schneider Optische Werke GmbH
Ringstraße 132
55543 Bad Kreuznach
☎ +49 671 601 205
✉ cs@schneiderkreuznach.com
www.schneiderkreuznach.com

Offices Worldwide

China

☎ +86 755 8832 1170
✉ shawn.liu@schneider-asiapacific.com

North America

☎ +1 800 645 7239 (East Coast)
☎ +1 800 228 1254 (West Coast)
✉ info@schneideroptics.com

Singapore

☎ +65 9488 0062
✉ thongv@schneiderkreuznach.com



945 East 11th Avenue Tampa, FL 33605

Phone: (813) 984-0125

Contact: Sales@pyramidimaging.com

<https://pyramidimaging.com>