

The Componon-S 2.8/50 (Version -0010A) is a 50 mm focal length enlarging lens with 43.2 mm image circle for large format sensors and short working distance. This lens can also be used in reverse position. The modular system with wide-ranging accessories such as helical focus barrel (Unifoc 58 and 76), extension tubes, and adapters for various cameras, can be used for all kind of sophisticated applications from web inspection to laser triangulation.

This, the fast F/# of 2.8 and low chromatic aberration, as well as extremely low distortion all combined make these lens unique. Vibration insensitivity for stable imaging performance even when the lens used in harsh industrial environmental, as common in OLED inspection and quality control systems. The Unifoc Series offers more enlarging lenses with 28 mm, 35 mm, 40 mm, 45 mm, 60 mm, 80 mm, 90 mm, 100 mm, 135 mm, 150 mm focal length and a macro lens series and a line scan lens series both for Unifoc 7 and 12 helicoid focus barrels.



Componon-S 2.8/50

## Key features

- Large format
- Short working distance
- Modular: Unifoc 58 and 76 focus helical barrels, extension tubes, various camera adapters
- Possibility to be used in retro position
- Vibration insensitivity for stable imaging performance

## Applications

- Solar inspection
- OLED inspection
- Line scan applications
- Laser triangulation
- Quality control

Name	Componon-S 2.8/50
Type	-0010
Focal Length [mm]	50
Magnification	-0.5
Image circle [mm]	43.2
Resolution [ $\mu\text{m}$ ]	3.65
F/# range	2.8 ... 16
NA	0.18
Interface	Leica-Mount
Working distance [mm]	131
AoV [°]	47
Focus control	manual
Transmission [nm]	400 - 1000
Filter thread [mm]	M43 x 0.75
Dimensions L x D [mm]	40.6 x 46.0

Name	Componon-S 2.8/50
Weight [g]	105
Storage temperature [°C]	-25 ... +70
$f'_{\text{eff}}$ [mm]	50.15
$S_F$ [mm]	-33.61
$S'_F$ [mm]	31.68
HH' [mm]	-3.07
$\beta'_p$	0.943
$S_{EP}$ [mm]	19.56
$S'_{AP}$ [mm]	-15.61
$\Sigma d$ [mm]	31.93
ID	16828

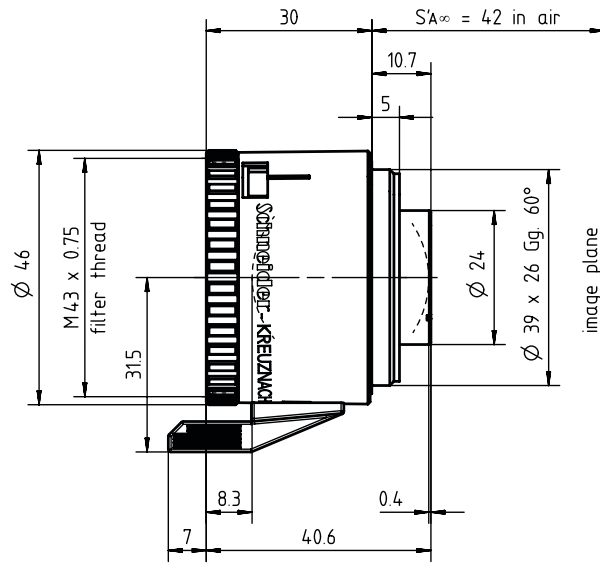

Distortion vs. Image Height

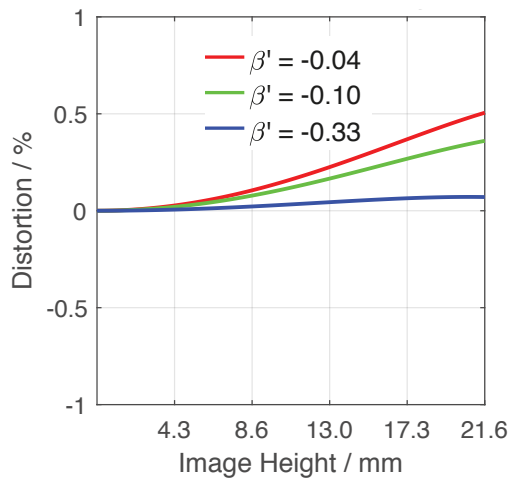

Transmittance vs. Wavelength

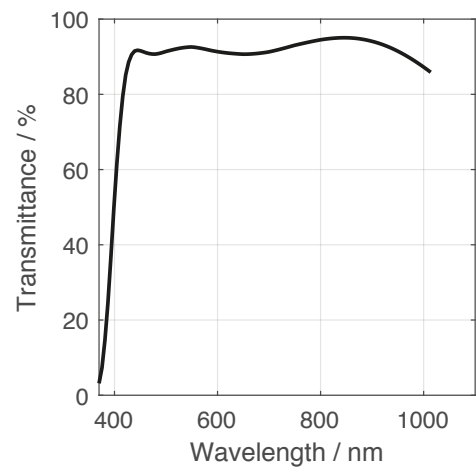

Relative Illumination vs. Image Height

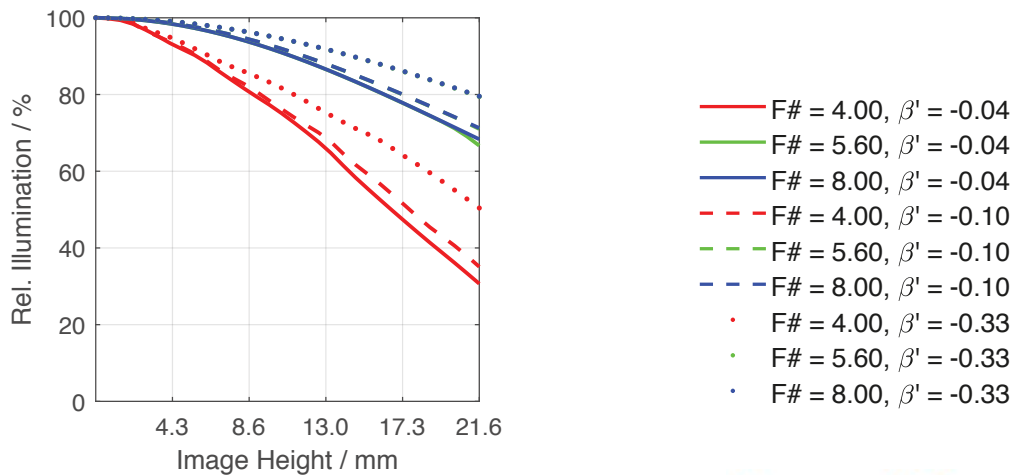

Spectrum Name	VIS					
Wavelengths [nm]	425	475	525	575	625	675
Weights	8	16	23	22	19	13

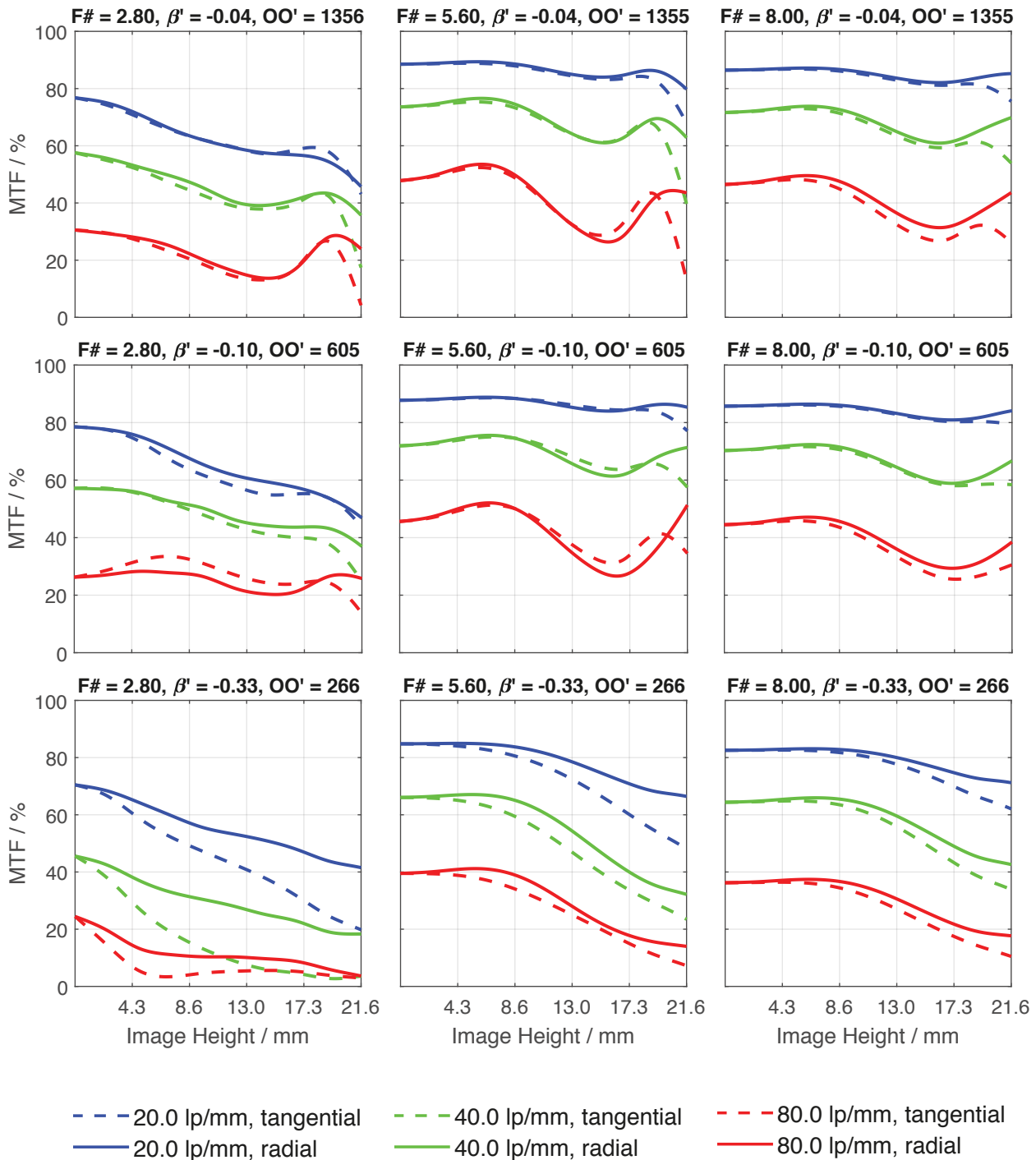

Accessories	Mount	Length	ID
Macro	UNIFOC 58 Leica / T2	-	39549
	UNIFOC 76 Leica / M58 x 0.75	-	13048
Ext. Tube	T2 / T2	25 mm	41643
	M58 x 0.75	10 mm	13051
	M58 x 0.75	25 mm	13050
	M72 x 0.75	5 mm	1072420
	M72 x 0.75	10 mm	1072421
	M72 x 0.75	25 mm	26406
	M72 x 0.75	50 mm	1054733
	M95 x 1.0	25 mm	1062892
	M95 x 1.0	50 mm	1062893
	M95 x 1.0	100 mm	1062894
Adapter	M58 / M72 x 0.75	-	13052
	M58 / M95 x 1	-	1062891
	T2 / C-Mount	-	41629
	T2 / Nikon	-	21591
	M50 x 0.75 for CPN-S 135/150	-	17231

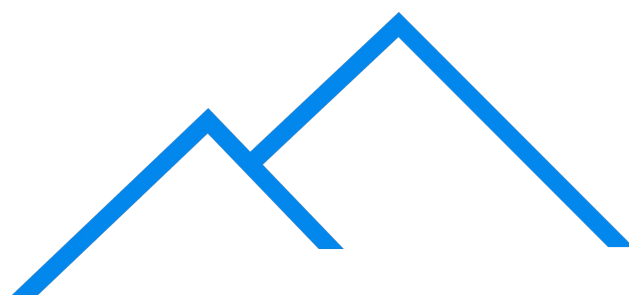

Pyramid Imaging

# Get more information

Contact our local offices



## Headquarter Germany

Jos. Schneider Optische Werke GmbH  
Ringstraße 132  
55543 Bad Kreuznach  
☎ +49 671 601 205  
✉ [cs@schneiderkreuznach.com](mailto:cs@schneiderkreuznach.com)  
[www.schneiderkreuznach.com](http://www.schneiderkreuznach.com)

## Offices Worldwide

### China

☎ +86 755 8832 1170  
✉ [shawn.liu@schneider-asiapacific.com](mailto:shawn.liu@schneider-asiapacific.com)

### North America

☎ +1 800 645 7239 (East Coast)  
☎ +1 800 228 1254 (West Coast)  
✉ [info@schneideroptics.com](mailto:info@schneideroptics.com)

### Singapore

☎ +65 9488 0062  
✉ [thongv@schneiderkreuznach.com](mailto:thongv@schneiderkreuznach.com)



945 East 11<sup>th</sup> Avenue Tampa, FL 33605

Phone: (813) 984-0125

Contact: [Sales@pyramidimaging.com](mailto:Sales@pyramidimaging.com)

<https://pyramidimaging.com>