

M1214-MP2

f=12mm F1.4

for 2/3 type Megapixel Cameras

C-Mount

Model No.		M1214-MP2		Effective	Front	φ 21.0mm	
Focal Length		12mm		Lens Aperture	Rear	φ 130mm	
Max. Aperture Ratio		1:1.4		Distortion	2/3type	-0.1%(γ=5.5)	
Max. Image Format		8.8mm x 6.6mm(φ 11mm)			1/2type	-0.35%(γ=4.0)	
Operation Range	Iris	F1.4 - F16C		Back Focal Length		13.1mm	
	Focus	0.15m - Inf.		Flange Back Length		17.526mm	
Control	Iris	Manual		Mount		C-Mount	
	Focus	Manual		Filter Size		M30.5 P=0.5mm	
Object Dimension at M.O.D	2/3 type	12.1 cm x 9.0cm		Dimensions		φ 33.5mm x 28.2mm	
	1/2 type	8.8cm x 6.5cm		Weight		61.9g	
Angle of View	D	2/3 type	49.2°	1/2 type	37.0°		
	H		40.4°		30.0°		
	V		30.8°		22.7°		
Operating Temperature		-10°C - +50°C					

M.O.D : Minimum Object Distance

Dimensions

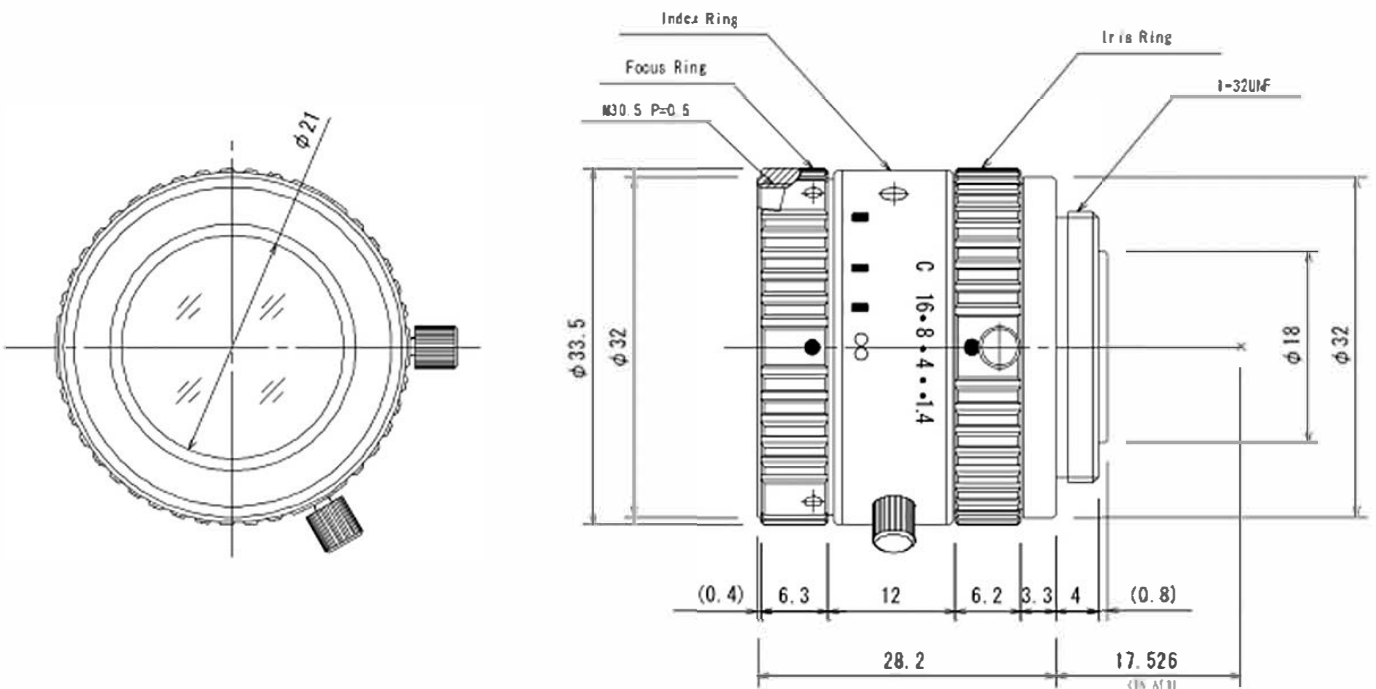

945 East 11th Avenue Tampa, FL 33605

Phone: (813) 984-0125

Contact: Sales@pyramidimaging.com

<https://pyramidimaging.com>

