

MLM-3XMP

0.3X - 1.0X
for 2/3 type Cameras, Megapixel Macro Zoom
C-Mount

2/3
type

C

Model No.		MLM-3XMP		Effective	Front	Ø15.5mm
Max. Magnification		0.3X - 1.0X		Lens Aperture	Rear	Ø7.0mm
Max. Aperture Ratio		1:4.5		Back Focal Length		20.4mm
Max. Image Format		8.8mm x 6.6mm(Ø11mm)		Distortion	2/3 type	0.3X Tele +0.02%(y=5.5)
Operation Range	Iris	F4.5 - F22C				1/2 type
	Focus	90mm		0.3X Tele -0.12%(y=4.0)		
Control	Iris	Manual		Flange Back Length		17.526mm
	Focus	Manual		Mount		C-Mount
	Zoom	Manual		Filter Size		M34 P=0.5mm
				Dimensions		Ø36.5mm x 79.5mm
				Weight		150g
Object Dimension at M.O.D.	D	2/3 type	36.7mm - 10.8mm	1/2 type	26.7mm - 10.8mm	
	H		29.4mm - 8.7mm		21.4mm - 6.4mm	
	V		22.1mm - 6.6mm		16.1mm - 4.8mm	
Angle of View	D	2/3 type	14.88° - 2.84°	1/2 type	10.70° - 2.72°	
	H		11.80° - 2.78°		8.48° - 2.18°	
	V		8.74° - 2.24°		6.38° - 1.64°	
Operating Temperature		-20°C - +50°C				

* For CS-Mount camera, please use 5mm adapter ring.
M.O.D.: Minimum Object Distance

Dimensions

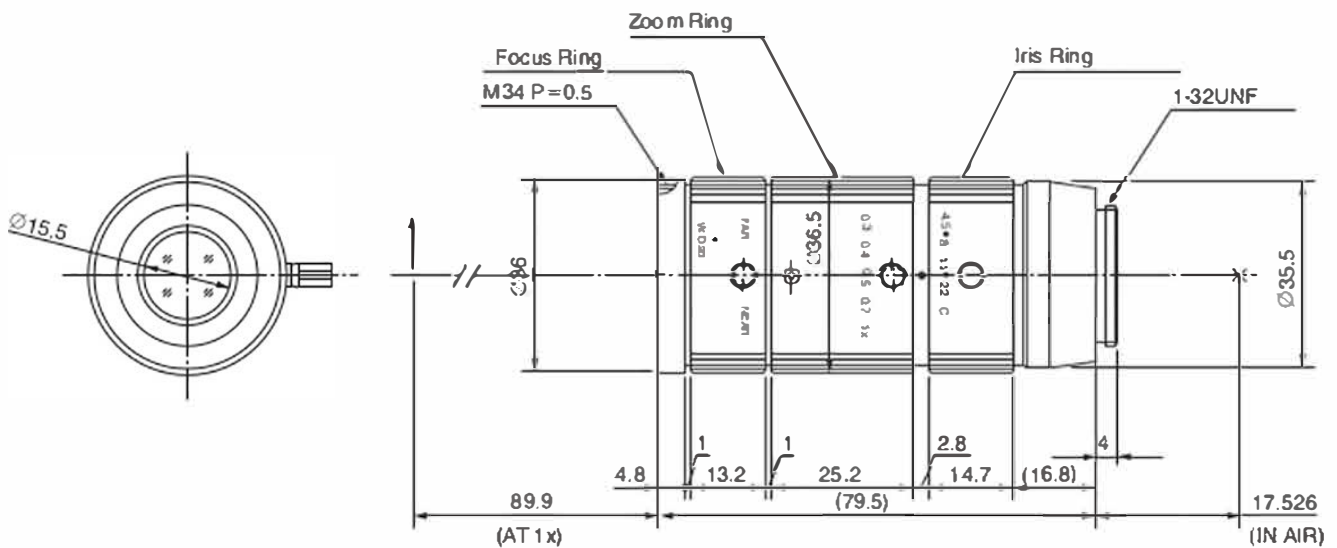

945 East 11th Avenue Tampa, FL 33605

Phone: (813) 984-0125

Contact: Sales@pyramidimaging.com

<https://pyramidimaging.com>

